

Loop^{SORG}



Instructions for use

Imprint

SORG Rollstuhltechnik GmbH + Co. KG
Benzstrasse 3-5
68794 Oberhausen-Rheinhausen / Germany

Phone +49 7254-9279-0
Fax +49 7254-9279-10
E-Mail info@sorgrollstuhltechnik.de
Web www.sorgrollstuhltechnik.de

Revision status

2023-01-27

Technical status

Technical changes and misprints reserved. The pictures in this instructions for use can differ from the actual equipment components. However, a corresponding conduction is possible.

Copyright

All texts, pictures and graphics underlie copyright protection. All rights, including copying, publishing, editing and translating, remain reserved. © by SORG Rollstuhltechnik GmbH+Co. KG Benzstraße 3-5, 68794 Oberhausen-Rheinhausen / Germany.

 Our terms and conditions can be found on our order forms and at www.sorgrollstuhltechnik.de/impressum

1	Seat shell-base-frame overview	5	4	Repairs/maintenance/reinstatement	38
			4.1	Repairs	38
2	General information	6	4.2	Spare parts	38
2.1	Preface	6	4.3	Maintenance	38
2.2	General information regarding instructions for use	6	4.4	Disinfection	38
2.2.1	Signs and Symbols	7	4.5	Storage	38
2.2.2	Intended purpose	8	4.6	Lifespan	39
2.2.3	Indication	8	4.7	Reinstatement	39
2.2.4	Contraindication	9	4.8	Disposal	39
2.3	General safety information	9	4.9	Maintenance/Inspection	39
2.3.1	Loading and transport without occupants	11	5	Technical data	41
2.3.2	Transport of the seat shell-underframe with passengers in a motor vehicle	11	5.1	Data and measurements	41
2.3.3	Other important information	13	5.2	Meaning of labels	42
			5.3	Declaration of conformity	42
3	Handling	15	6	Verification of yearly inspection	43
3.1	Handling driving wheel	15			
3.1.1	General information regarding wheels	15			
3.1.2	Tyre inflation pressure	15			
3.1.3	Quick-release axles	15			
3.1.4	Double hand rim-wheels	16			
3.2	Handling swivel caster	17			
3.2.1	General information regarding swivel casters	17			
3.2.2	Caster track lock	17			
3.3	Handling seat and back	18			
3.3.1	General information regarding back	18			
3.3.2	(Seating unit) tilt mechanism	18			
3.3.3	Back with gas pressure spring	19			
3.3.4	Seat shell	22			
3.4	Handling pushing aid	23			
3.4.1	General information regarding pushing aids	23			
3.4.2	Push bail	24			
3.5	Handling leg support	26			
3.5.1	General information regarding leg supports	26			
3.5.2	Foldable footrest with locking mechanism	27			
3.5.3	Detachable and swivelling leg support	28			
3.6	Handling brake	31			
3.6.1	General information regarding brakes	31			
3.6.2	Wheel lock	31			
3.6.3	Drum brake	32			
3.6.4	Reverse-roll locking	32			
3.7	Handling anti-tipper	33			
3.7.1	General information regarding anti-tipper	33			
3.8	Handling therapy table	34			
3.8.1	General information regarding therapy table	34			
3.9	Handling arm pad	35			
3.9.1	General information regarding arm pad	35			
3.9.2	Arm pad mounted on the back	35			
3.9.3	Arm pad mounted on the seat shell	35			
3.10	Handling steering & pushing aid	37			
3.10.1	General information regarding steering and pushing aids	37			

1 Seat shell-base-frame overview

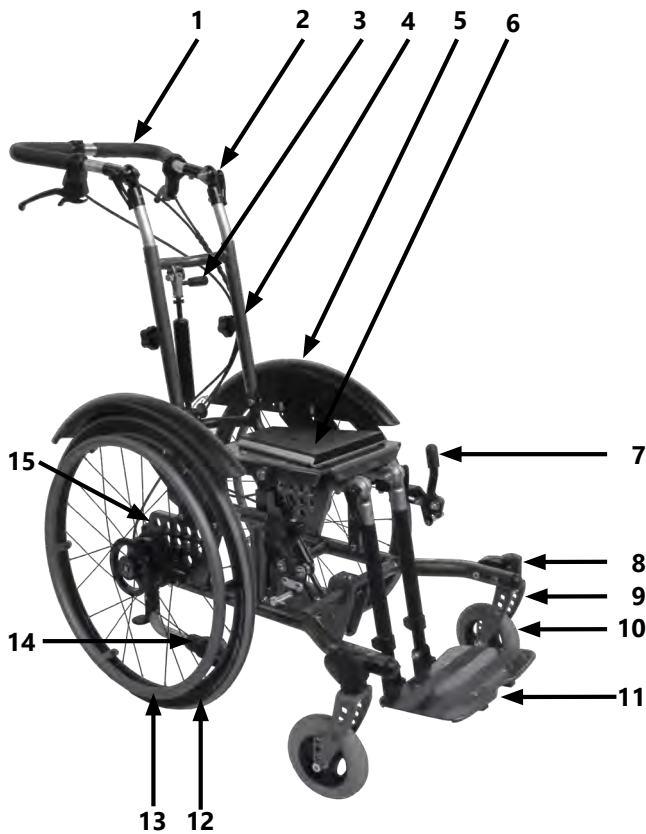

- 1 Push bail, height adjustable
- 2 Eccentric clamp for angle adjustment of the push bail
- 3 Gas pressure spring for angle adjustment of the back
- 4 Star grip for height adjustment of the push bail
- 5 Wheel cover
- 6 Wedge and intake
- 7 Brake lever
- 8 Caster adapter
- 9 Caster fork
- 10 Swivel caster
- 11 Footrest
- 12 Driving wheel
- 13 Handrim
- 14 Anti-tipper
- 15 Axle plate

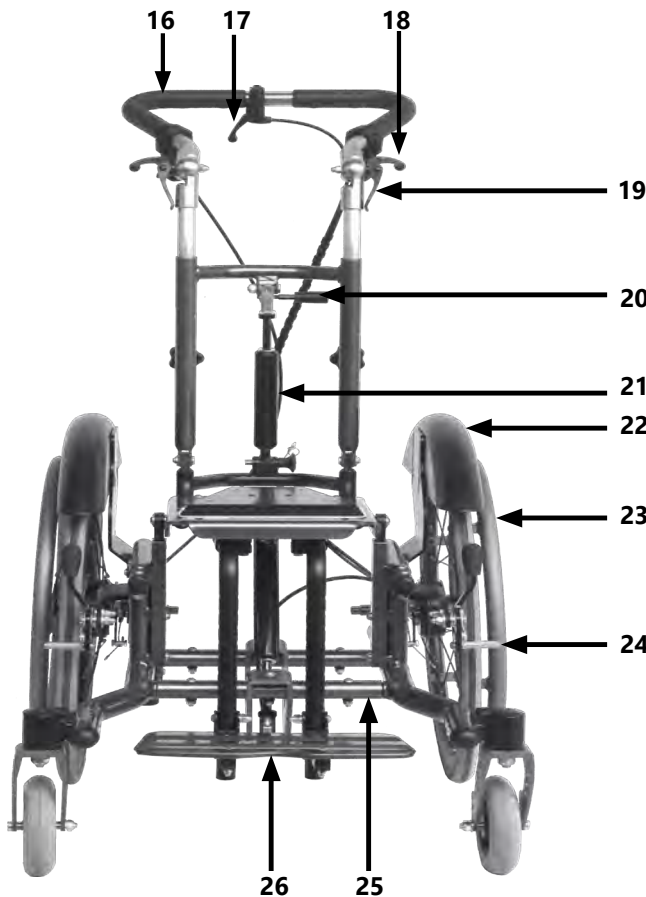

- 16 Push bail, height adjustable
- 17 Tripping lever for (seating unit) tilt mechanism
- 18 Operating lever for drum brake
- 19 Eccentric clamp for angle adjustment of the push bail
- 20 Operating lever for angle adjustment of the back
- 21 Gas pressure spring for angle adjustment of the back
- 22 Wheel cover
- 23 Handrim
- 24 Brake pressing bolt of the wheel lock
- 25 Cross beams for extending the frame
- 26 Footrest (can be folded backwards)

2.1 Preface

A warm welcome to the SORG family – many thanks for the trust you have placed in us and for choosing our product.

This seat shell-underframe has been individually tailored to meet your specific requirements.



You will find the usage and adjustment instructions below so that you can use the seat shell-underframe in everyday life without tools. Please observe these instructions and handle the seat shell-underframe carefully so that you can enjoy it for as long as possible.

Please do not hesitate to contact us if you have any questions about this or any other product.

We hope you enjoy using your SORG product.

Your SORG team

2.2 General information regarding instructions for use

These instructions for use contain safety information and handling instructions that are necessary for the correct use of the product.

All settings, adjustments and repairs beyond the scope of these instructions for use, and the annual inspection, must be carried out by a qualified specialist dealer.

You can find more information about this in our service record, which can be accessed at www.sorgrollstuhltechnik.de

The user and specialist dealer must have read and understood these instructions before commissioning. These instructions for use cover all equipment variants of the product. Have your consultant instruct you on the safe handling of the seat shell-underframe and your individual equipment variants on level ground and with the support of an accompanying person.

 Those with impaired vision can find these instructions for use on our website www.sorgrollstuhltechnik.de as PDF and audio files.

Please contact your specialist dealer or our team if you have any questions or comments (+49 7254 9279-0).

Keep these instructions for use in a safe place. All annual inspections carried out must be documented by the specialist dealer.

2 General information

2.2.1 Signs and Symbols



ATTENTION! Warnings for personal Safety aspects that are of the utmost importance.



CORRECT safety adjustment/ use



INCORRECT adjustment /use



NOT ALLOWED



References to additional/ continuing reading.



important detail



correct or proper use/setting



incorrect or improper use/setting

(A); (B)

reference from text to detail

USE



push/ pull/ insert/ move/ remove



Push in specific direction



Setting or adjusting the angle



open/close



Turn clockwise



Turn counterclockwise



steps to be done at the same time

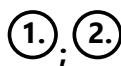

steps to be done after each other



Steps to be done on both sides



View

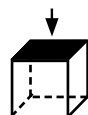

view from top



view from the side



view from the bottom



view from the front

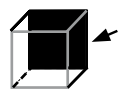

view from the back



fasten parts



remove parts

2.2.2 Intended purpose

The Loop^{SORG} is a partially growable seat shell-underframe for children, young people and adults intended for indoor and outdoor use.

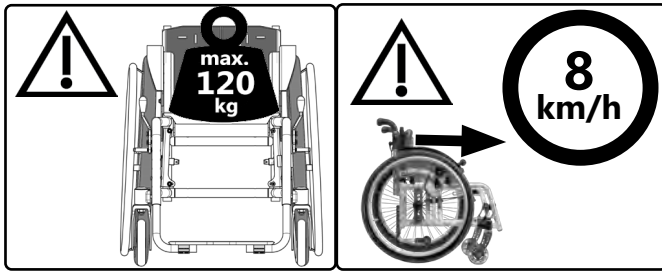



The seat shell-underframe is designed solely for the transport of the person for whom it has been specially adapted by a qualified specialist dealer.

Parents or authorised guardians must ensure that the information in the instructions for use is followed for children or persons with impaired capacities.

The safest possible use of the aid is only possible on level, firm and dry ground with the anti-tipper activated and with the help of an accompanying person.

 Any use beyond this entails taking a variety of risks for which only the user themselves can take responsibility. This requires sufficient competence in identifying and avoiding hazards and safe handling of the aid by the user! An increased hazard potential must be taken into account, especially in wet conditions, ice, loose ground, slopes, obstacles, close proximity to water, road traffic, narrow spaces, etc.

 Only use the seat shell-underframe for its intended purpose. Any improper use of the product involves considerable risks and will invalidate product liability.

 The large variety of combinations for seat and wheel position means that settings can be made that are outside the safety and application range.

2.2.3 Indication

Use is suitable for the following, among others:

- in the paediatric and geriatric field for all types of therapy for alternating placement and positioning of immobile or mobile persons,
- in residential and inpatient environments for straightening patients from a lying position to an upright sitting position and for preserving and/or developing residual functions,
- for stimulation and strengthening of the complete metabolism, the vegetative nervous system and/or the complete cardiovascular system,
- for activation, preservation and development of the entire tonicity or individual muscle groups,
- for rehabilitation after serious (craniocerebral) trauma,
- for building up and strengthening the entire skeleton,
- for slowing down progressive scoliotic developments,
- for regulating all forms of dyskinesia (e.g. lack of/restricted head control),
- for all dystrophic or atrophic changes in the musculature,
- for all forms of paresis and/or neuromuscular conditions.

2 General information

2.2.4 Contraindication

Active use is unsuitable for:

- users with skin that is not intact,
- serious tonus dysregulation.

We accept **no** liability for damage to persons or objects resulting from the circumstances described above.

2.3 General safety information

- Before each use, check:**
- the frame, back tubes, add-on parts and accessories for visible damage, bending, cracks or missing or loose screws,
 - the wheels and quick-release axles for tightness,
 - that the inflation pressure and tyre tread are sufficient,
 - that the brakes are working properly,
 - that the angle adjustment elements/ eccentric clamps are secure,
 - that the seat plate/ back/ footrest are tightly locked,
 - that the anti-tipper/seat and back belts are functioning correctly,
 - that all previously dismantled components have been reconnected and firmly locked.

There is a risk of injury (e.g. due to crushing) from all rotating, swivelling or foldable components, even during adjustment and repair work and during transport.

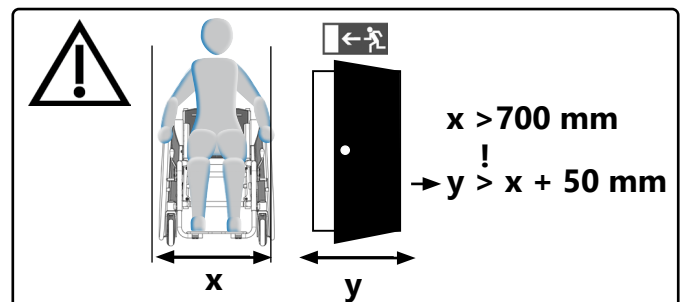
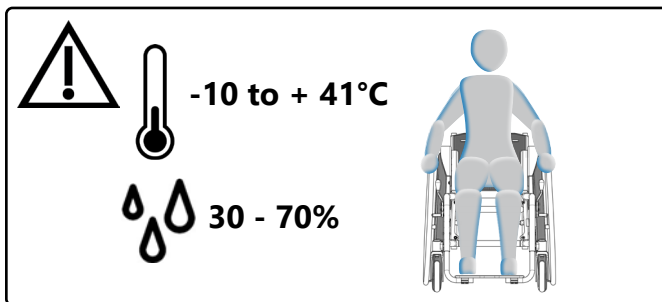

Danger of tipping over and overturning

Occupants must only get in and out of the seat-shell underframe with the wheel lock and anti-tipper engaged.

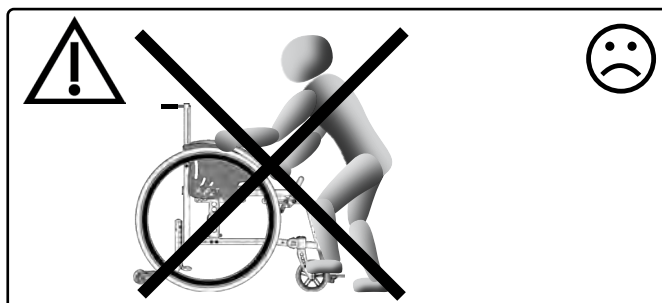

Do not use the footrest(s) for getting in and out of the seat shell-underframe, it may tilt forward.

- The risks listed as examples below may occur when dismantling the following parts/accessories:
- Footrest: legs jammed during transport
 - Headrest: loss or missing during transport
 - Arm rests: loss during transport
 - Seat shell adapter: loss or no attachment of the seat shell during transport possible
 - Seat shell back guide: loss or misalignment of the seat shell during transport possible
 - Push bail: loss or missing pushing option during transport

2 General information

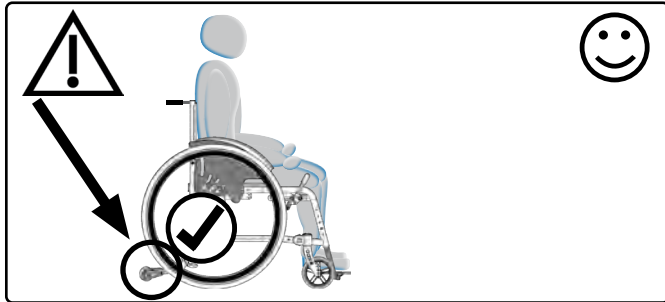
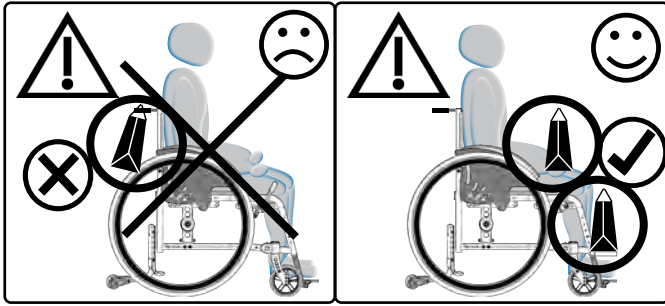

⚠ We strongly recommend the use of the anti-tipper.

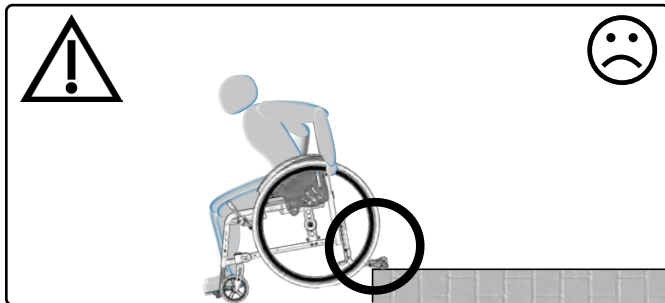

⚠ The anti-tipper must be deactivated when moving down over edges.

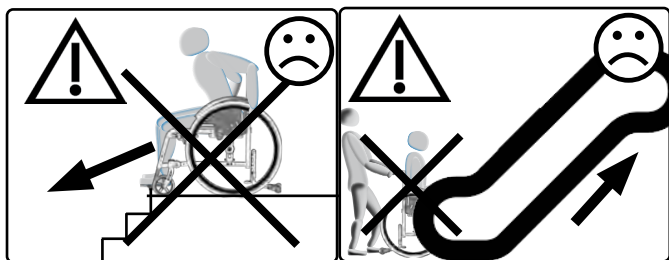
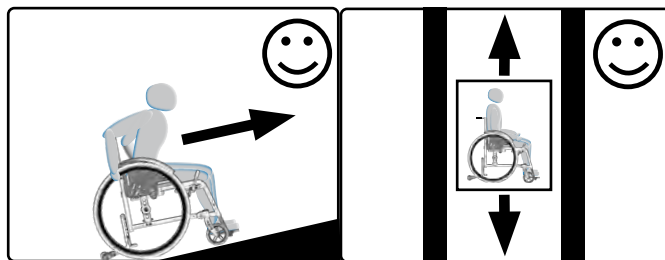

⚠ Only negotiate stairs with the help of experienced assistants. The anti-tipper must be deactivated when doing so. The seat-shell underframe must always be carried by the **frame only**, **never** by the seat shell, the extendable push handle(s), push bail, handle bar, leg supports and/or the footrest(s)!

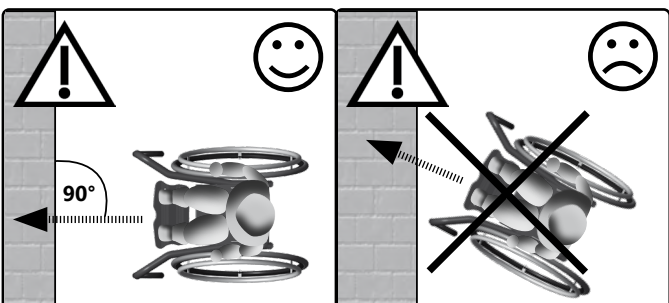
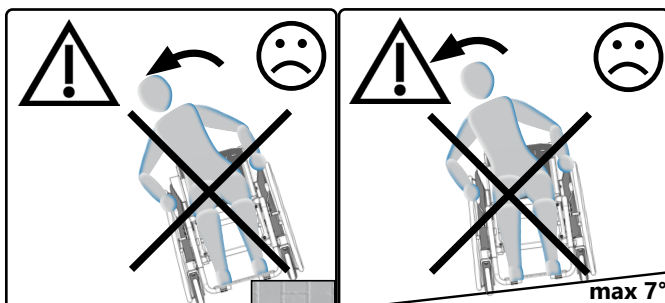

2 General information

Inclines, downward gradients and obstacles

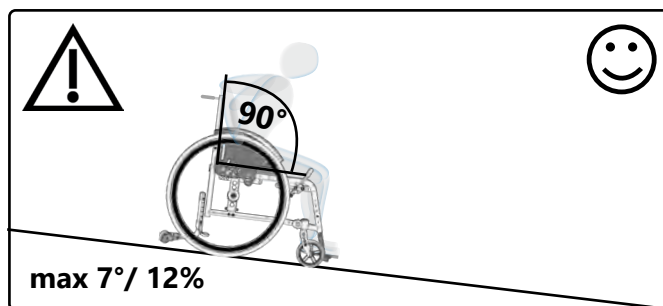
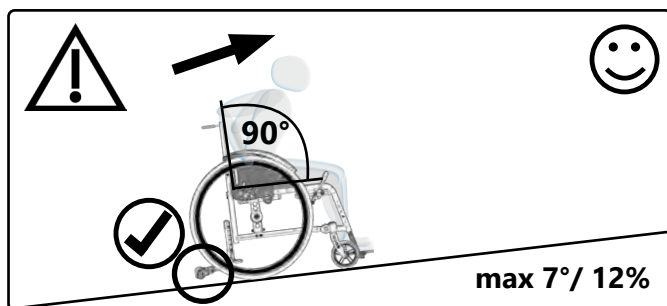

2.3.1 Loading and transport without occupants

Make sure that the packing size you require is suitable and secure the seat shell-underframe and all dismantled components with sufficient load securing. The seat-shell underframe is suitable for transport (land/air) in principle. Inform yourself about suitable load securing precautions before transport.

Carrying points:

- Frame tubes, rear l/r
- Frame tubes, front l/r
- But **not** on the footrests.

2.3.2 Transport of the seat shell-underframe with passengers in a motor vehicle

The characteristics of seat shell-underframes mean that they can never achieve the stable properties of a fixed seating system in a vehicle. Wherever possible, we recommend using a fixed vehicle seat to transport a person in a motor vehicle.

Only seat shell-underframes that have successfully passed a crash test in accordance with ISO 7176-19 may be used as seats in motor vehicles. Successfully tested seat shell-underframes and wheelchairs are provided with the symbol for the attachment point on the affixed nameplate.



The Loop^{SORG} has been successfully tested in accordance with ISO 7176-19 and is therefore approved for use as a seat in a motor vehicle provided that it is fitted with the necessary restraint systems.



Please check whether your seat shell-underframe is custom-made because it may not be suitable for use as a seat in a motor vehicle. If this is the case, the symbol for the attachment point will be missing from the nameplate and the seat shell-underframe will be marked with a warning, represented by the negated symbol for the attachment point.



More information can be found in the crash test brochure at www.sorgrollstuhltechnik.de/downloadportal.

We can recommend the following manufacturers of restraint systems:

- SORG restraining eyelets on wheelchairs
- AMF-BRUNS GmbH & Co.KG
- Q'Straint Europe

Attachment points/methods for transport in motor vehicles

 When using the seat shell-underframe as a seat in a motor vehicle, only the positions marked with the symbol for the attachment point should be used. These can usually be found at the back left and right **(1)** and at the front left and right. **(2)**

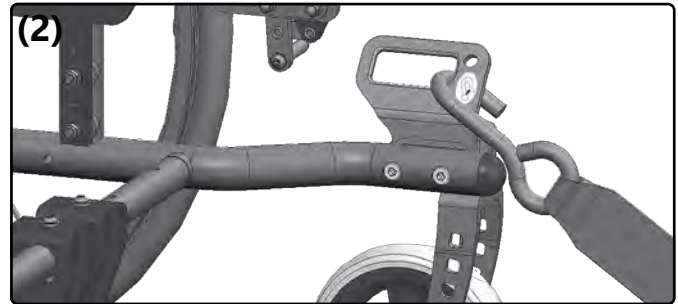
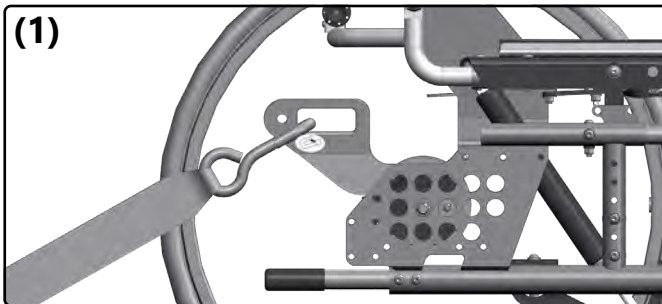

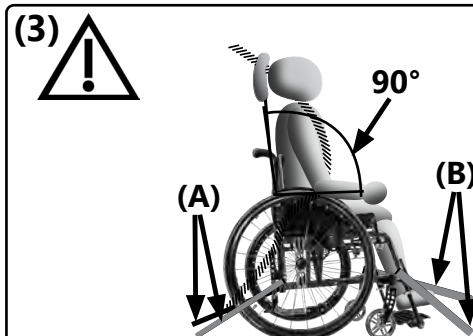

 The seat shell-underframe must be fixed with a 4-point wheelchair restraint system anchored to the vehicle in accordance with ISO 10542. These may be carabiner hooks, S-shaped hooks or plug-in fasteners. The wheelchair restraint system must be securely fastened and used in accordance with the user manual of the manufacturer. **(3A+B)**

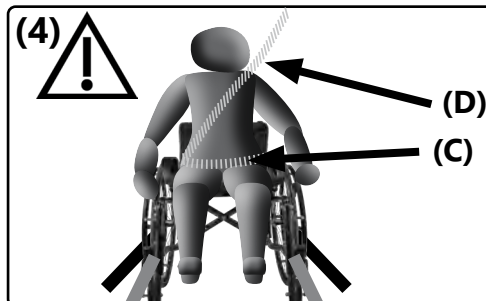

 If the seat shell-underframe is equipped with a back angle-adjustment or tilt mechanism, the occupant must sit in an upright position at a 90° back angle during transport **(3)**. Leg supports that can be swung up must be adjusted to the lowest position.

 The user must be additionally secured with a fixed lap belt **(4C)** approved for transport in accordance with ISO 10542 and a vehicle-anchored shoulder belt **(4D)** so that the risk of head and upper body injuries can be minimised to the greatest extent possible.





 The seat belts must not be twisted during use, nor must they be guided over any structural components, which would keep them away from the body. They have to be tight and firm without impairing user comfort. The lap belt buckle must be positioned between the pelvic bones (if possible in the middle). The buckle tongues on the lap belt for fastening the shoulder belt should be located on the outside of the pelvis where possible.

 All belts used for transport must be regularly inspected for damage.

 A headrest suitable for transport must be used.

 The seat shell-underframe must only be used as a forward facing seat in motor vehicles in accordance with ISO 7176-19. No transport with the seat shell-underframe facing sideways!

 Immediately contact your authorised dealer after a collision to check the carriage, frame and brakes and have any damage repaired by a specialist without delay.

 Any braking devices fitted to the seat shell-underframe must be in the braked position when the seat shell-underframe is transported in the motor vehicle.

2.3.3 Other important information

 The seat shell-underframe has been tested and verified for resistance to ignition of textile materials in compliance with the applicable standards. Nevertheless, there is a risk of ignition of the flame-retardant textile components. Keep any sources of ignition away from the seat shell-underframe.

 The seat shell-underframe must neither be exposed to excessive moisture nor come into contact with salt water.

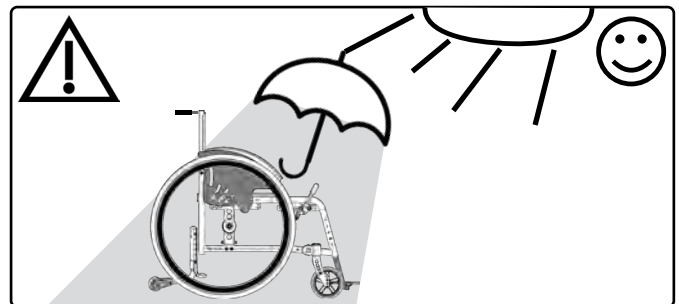
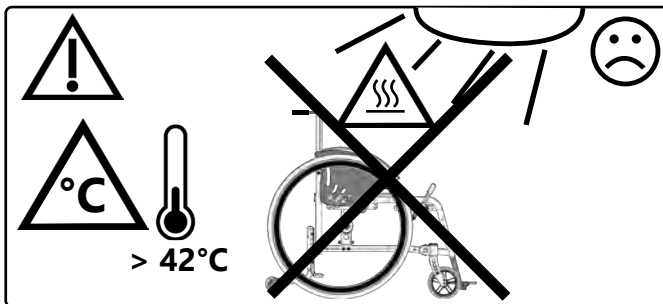

When configuring the seat shell-underframe, pelvic restraints (lap belts as positioning aids) can be optionally purchased via the SORG order sheets or by ordering from the replacement parts catalogues. Your specialist dealer will carry out the assembly.

The product may interact with electromagnetic fields (e.g. shop anti-theft devices) in individual cases. This poses no danger to the user and/or the attendant.

The wide variety of settings available means that not all limit values can be complied with in all possible configurations in accordance with the *Regulation (EU) on the technical specifications for interoperability relating to accessibility of the Union's rail system for persons with disabilities and persons with reduced mobility*.

Please contact your specialist dealer or us as the manufacturer if you experience any issues with the seat shell-underframe. Product recalls etc. will be published on our website www.sorgrollstuhltechnik.de. You can also find the respective contact persons there.

Corrosion protection

The product has been designed with corrosion protection in mind when selecting the materials (e.g. plastic, aluminium, stainless steel). All materials prone to corrosion are surface-treated and are therefore protected.

The seat shell-underframe must be dried thoroughly if it becomes wet.

Lifespan

 Use beyond the specified lifespan increases the residual risks and should only be carried out after careful, qualified consideration by the operator. If the useful life is reached, the user or a responsible person should contact the specialist dealer. There you can be informed about the possibility of reprocessing the product.

Combination with products from other manufacturers

 The wheelchair may only be combined with the electrical auxiliary drives approved by the manufacturer. The responsibility of restrictions or adjustments as well as the attachment itself lies with the supplier of the additional system or the specialized retailer. Please ask about the conditions with the manufacturer of the auxiliary drives.

 In combination of wheelchair and electric auxiliary drive, certain strains occur that can lead to damage to the wheelchair. Slowly approach obstacles and carefully overcome them so that little force is applied to the casters, rear wheels and the wheelchair as a whole.

3.1 Handling driving wheel

3.1.1 General information regarding wheels

Frictional heat is generated by braking the wheels on the handdrims.

Handrim covers can stretch when exposed to heat and become detached from the handrim.

3.1.2 Tyre inflation pressure

You can find the right operating pressure on the tyre casing - usually 3-10 bar. **(1)**

If the tyre is flat, please contact your specialist dealer.



3.1.3 Quick-release axles

Remove:

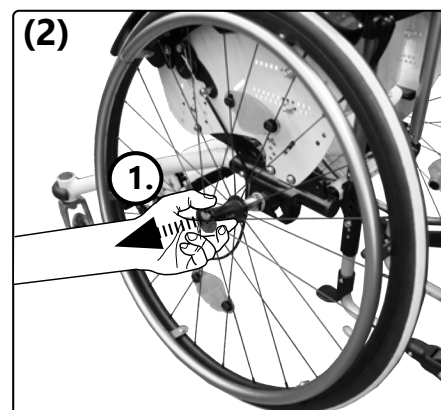
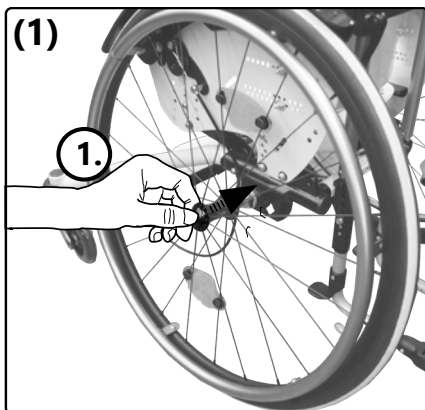

Insert:

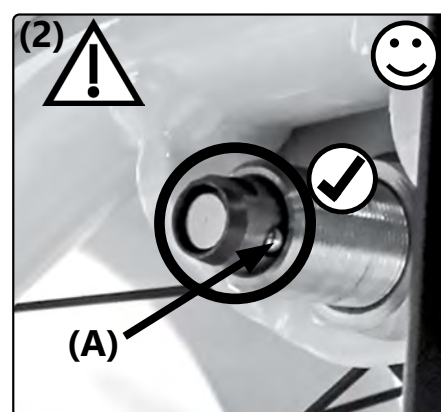
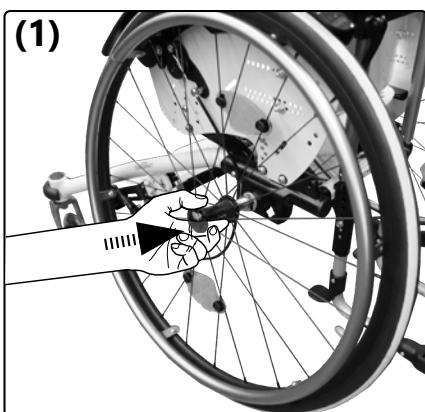

(2) After insertion, the locking ball **(A)** must be visibly protruding. Pull at least 1x after each insertion to test whether the quick-release axle is engaged. It should no longer be possible to pull the wheels outwards.

3.1 Handling driving wheel

3.1.4 Double hand rim-wheels

Insert:

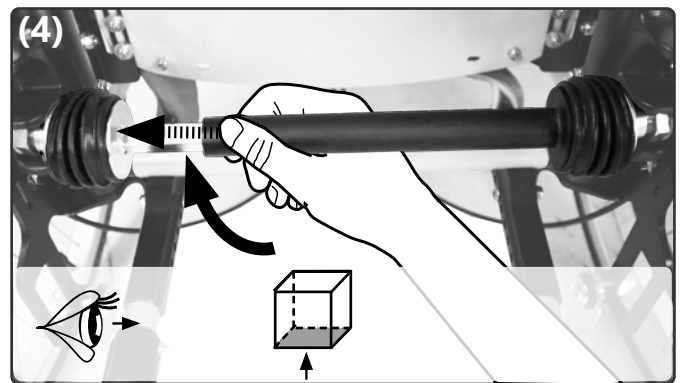
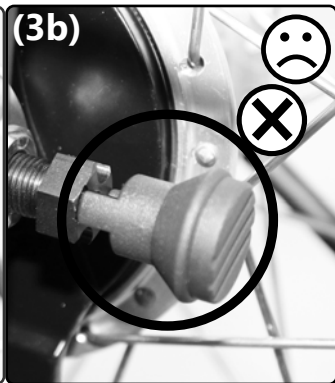
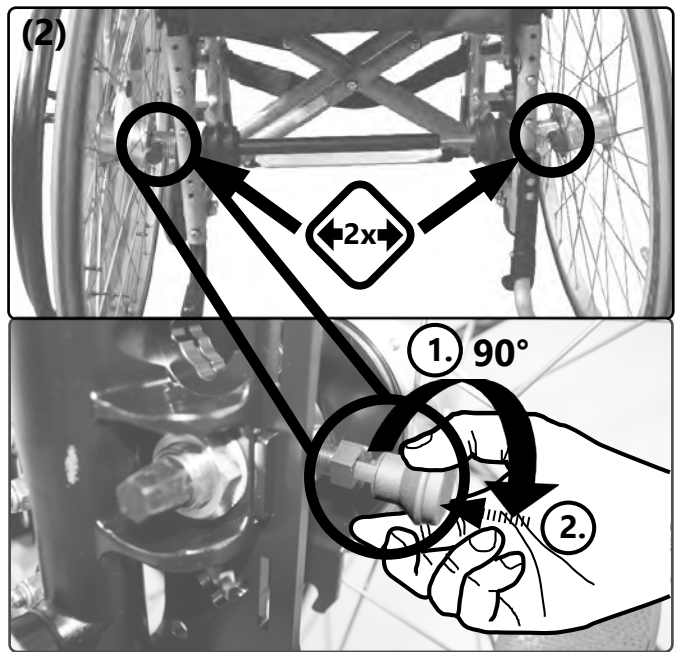
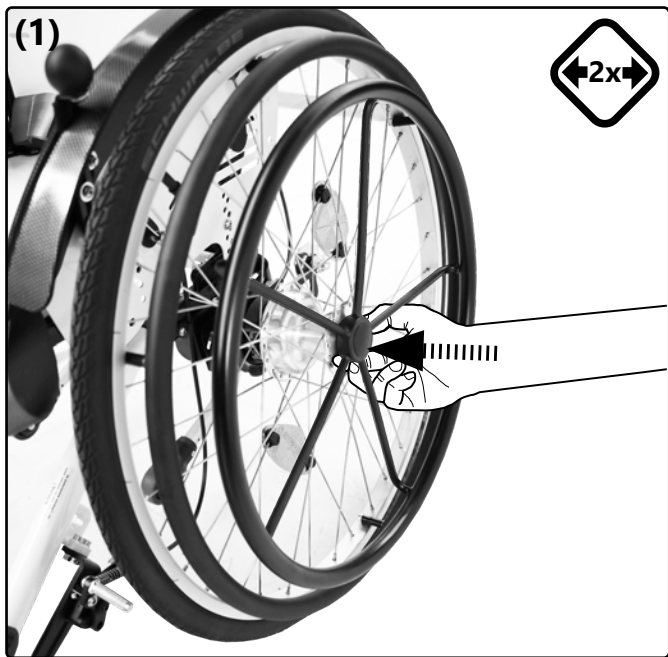

Remove: Proceed accordingly in reverse order

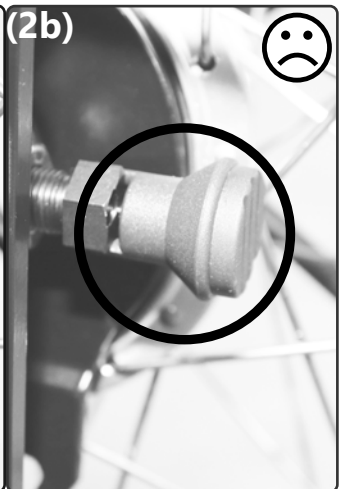
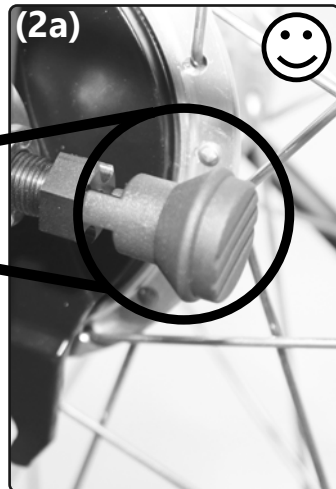

3.2 Handling swivel caster

3.2.1 General information regarding swivel casters

Incorrectly adjusted swivel casters or excessive speed can cause the casters to flutter. Immediately slow down at the first sign of fluttering and have the swivel casters readjusted by a specialist dealer.

3.2.2 Caster track lock

Unlock:

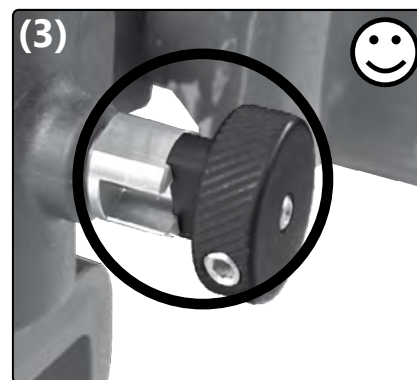
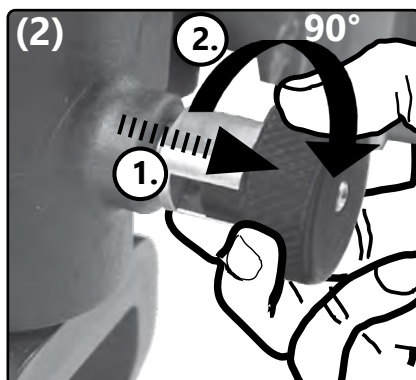
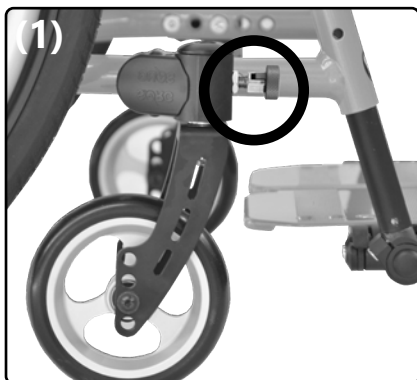

Lock:

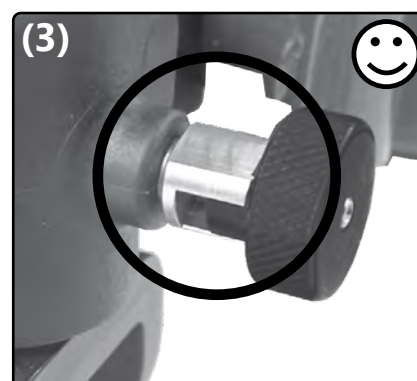
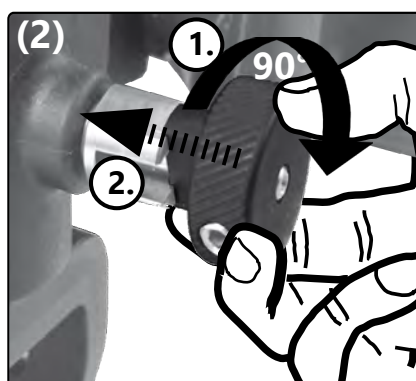
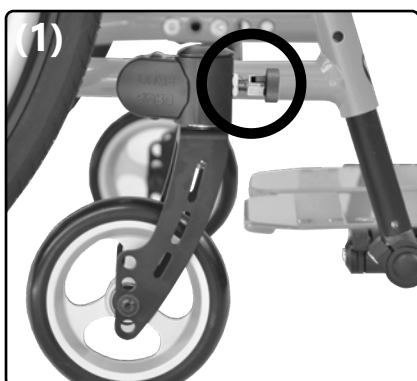

3.3 Handling seat and back

3.3.1 General information regarding back

Check the secure fit of the back after each change.

In the case of angle adjustable backs or (seating unit) tilt mechanisms, it is essential to activate the anti-tipper from a setting of $> 90^\circ$. The head must be supported (e.g. by a headrest) during back angle-adjustment or tilting.

Only activate the (seating unit) tilt mechanism or angle adjustment when stationary with the brakes applied.

3.3.2 (Seating unit) tilt mechanism

Tilting simple gas pressure spring:



Tilting double gas pressure spring:

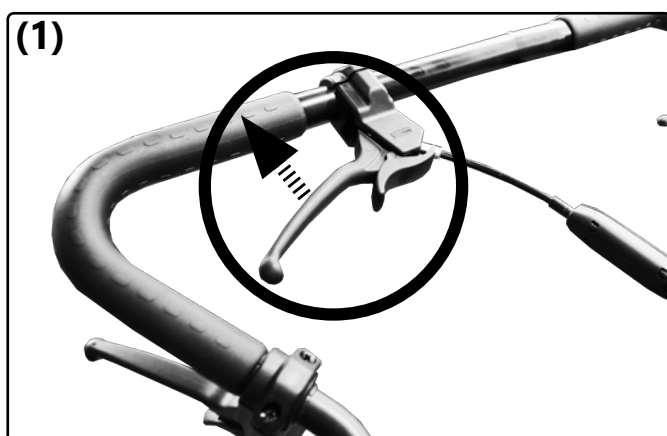

3.3 Handling seat and back

3.3.3 Back with gas pressure spring

Shift:

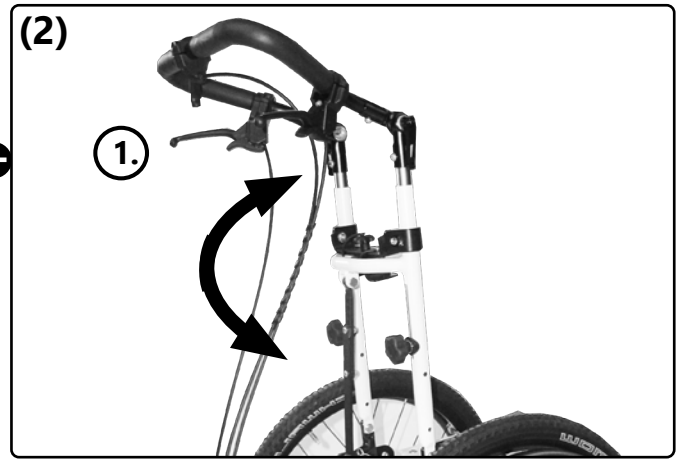
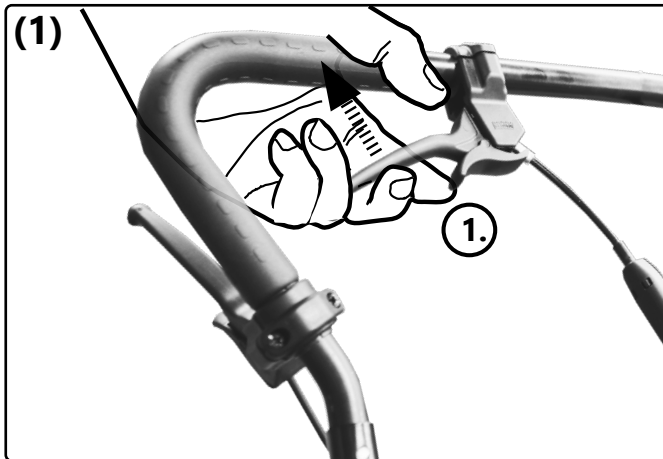

3.3 Handling seat and back

Folding down back with gas pressure spring:

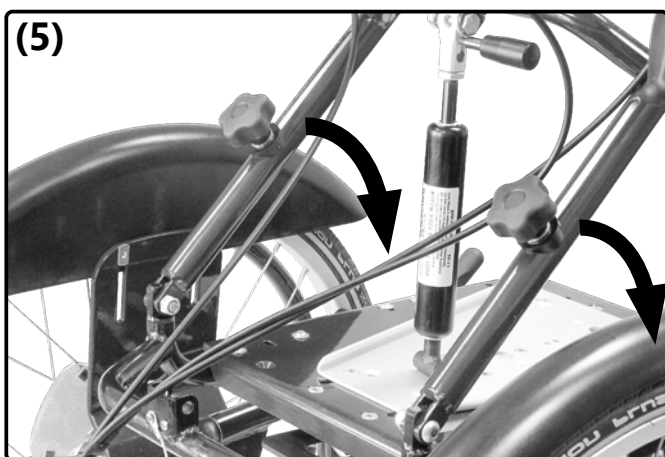
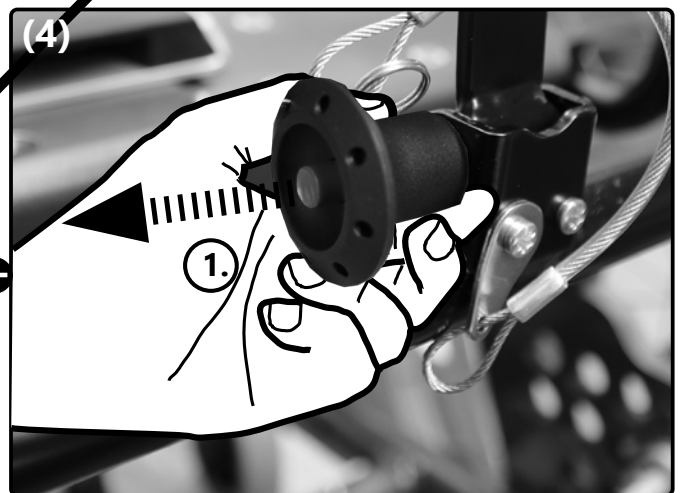
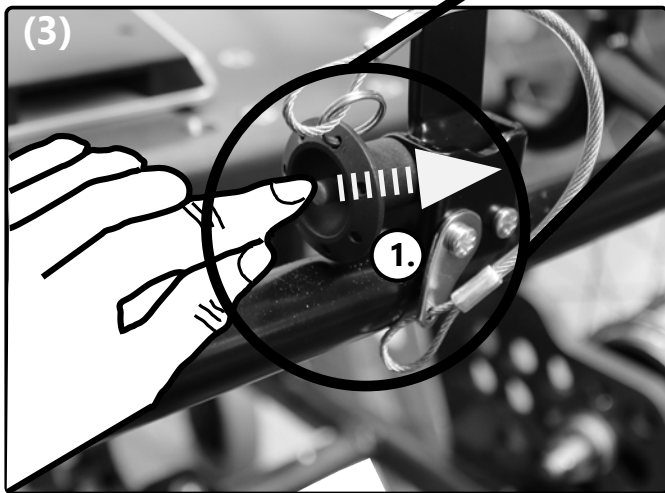
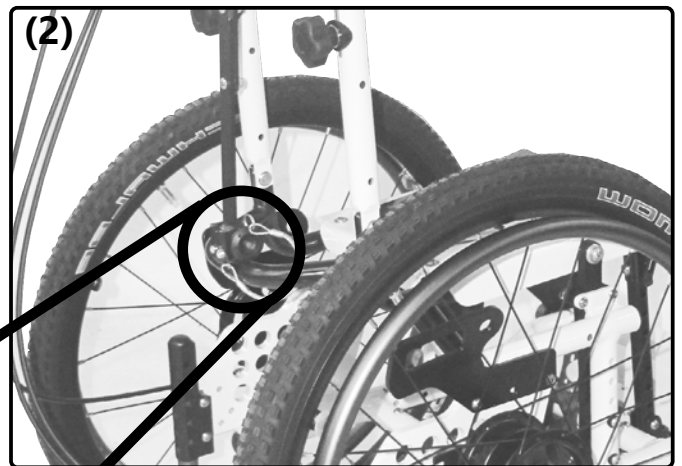
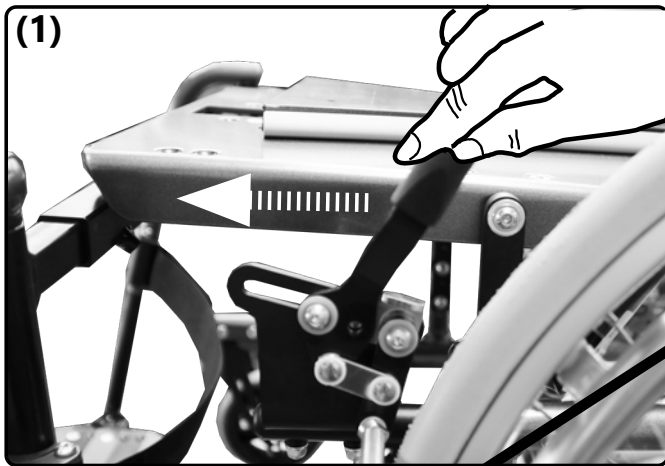

Folding open back with gas pressure spring: Proceed accordingly in reverse order:

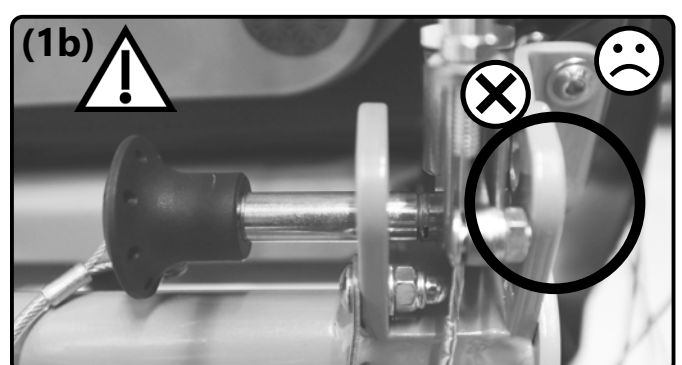
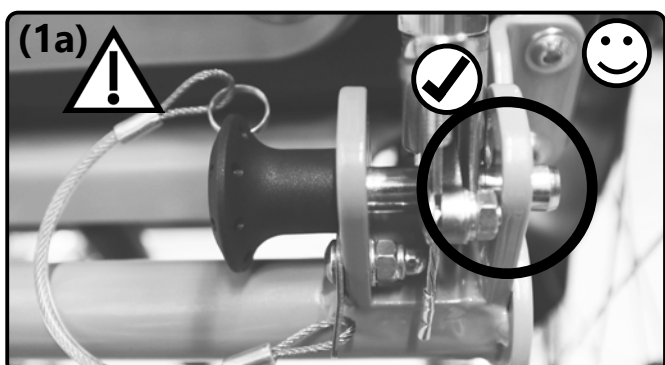

3.3 Handling seat and back

Adjust angle for back with gas pressure spring:

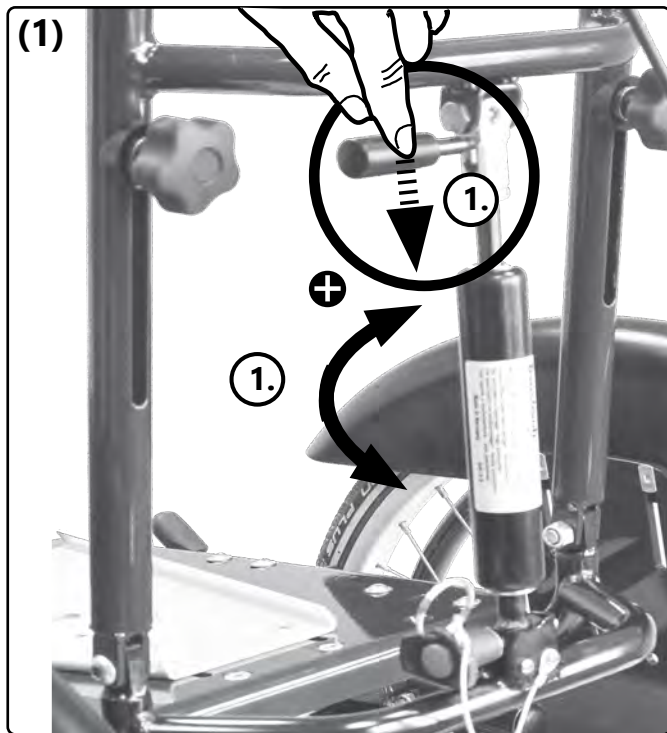

3.3 Handling seat and back

3.3.4 Seat shell

Insert/lock:

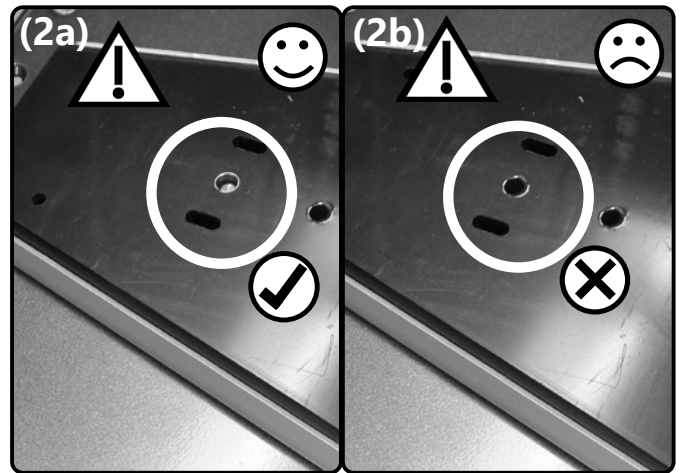
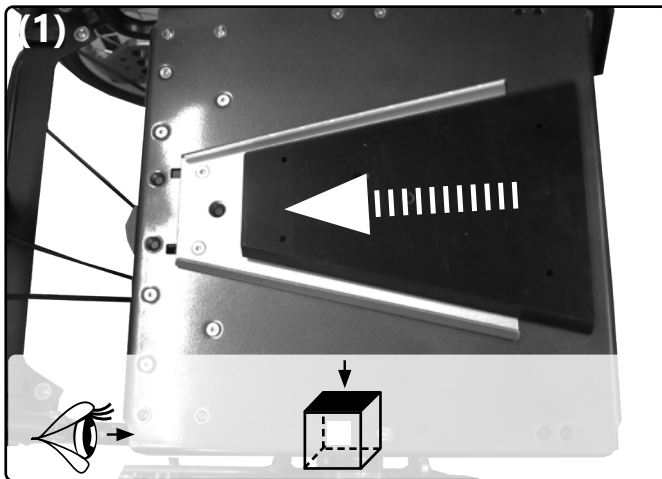

⚠ Ensure that the seat shell is firmly anchored to the seat plate and cannot be pushed forward.

Remove:

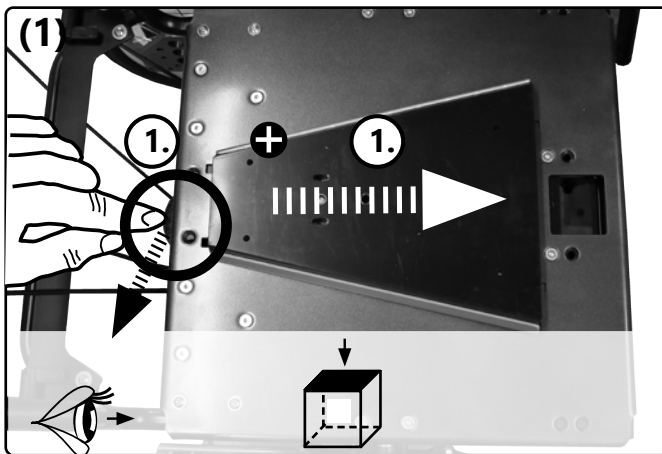

Connect back guide (remove: proceed accordingly in reverse order):

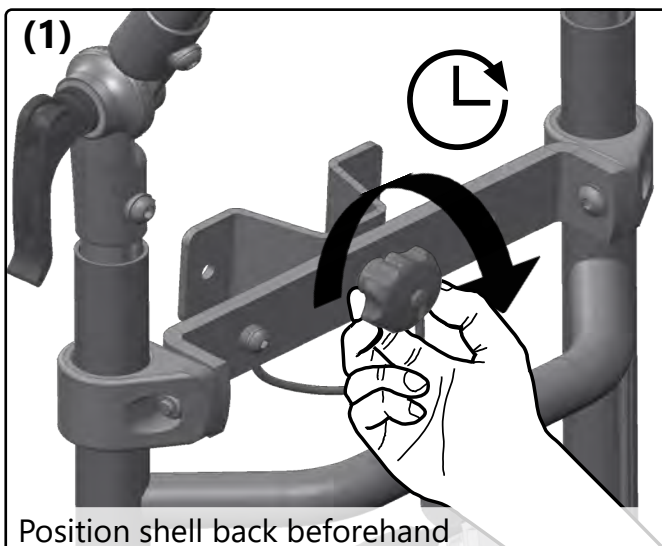

Position shell back beforehand

3.4 Handling pushing aid

3.4.1 General information regarding pushing aids

All height adjustable pushing aids are designed exclusively to push the occupant in their seat shell-underframe – **not to carry them**.

Children are not able to competently judge the swivel range of protruding pushing aids and may injure others while playing. We recommend folding back or dismantling the pushing aids in such cases.

Check that the eccentric clamps are tightly closed and in good working order before each use of the pushing aids. It must not be possible to move the pushing aids in the intake with the eccentric clamp(s) in the closed position.

Set the eccentric clamp:

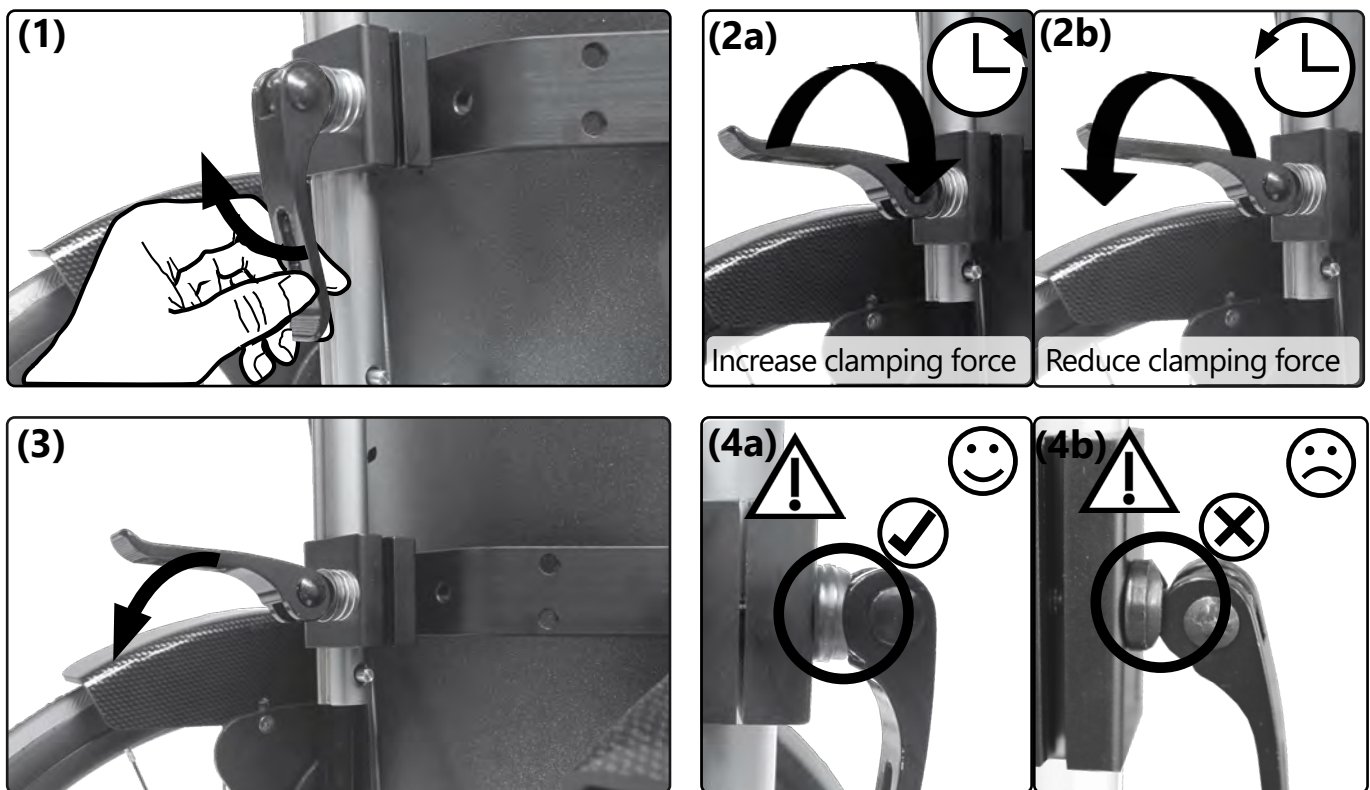

3.4 Handling pushing aid

3.4.2 Push bail

Set height:

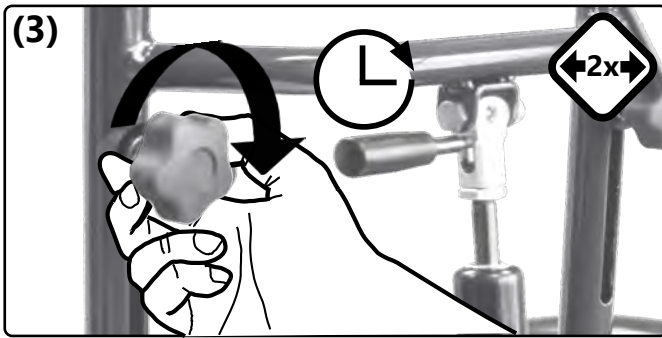
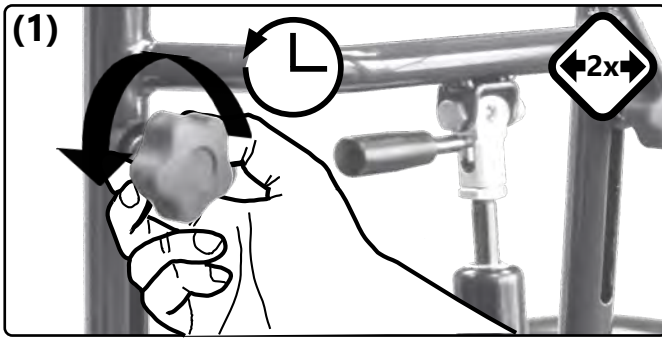

3.4 Handling pushing aid

Adjust angle:

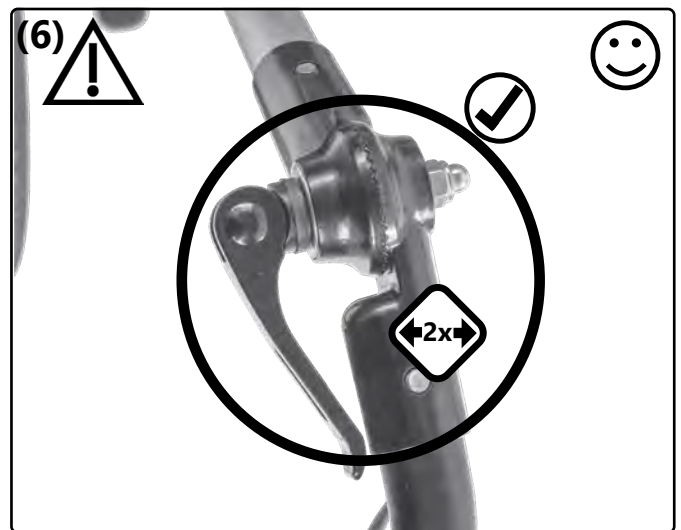
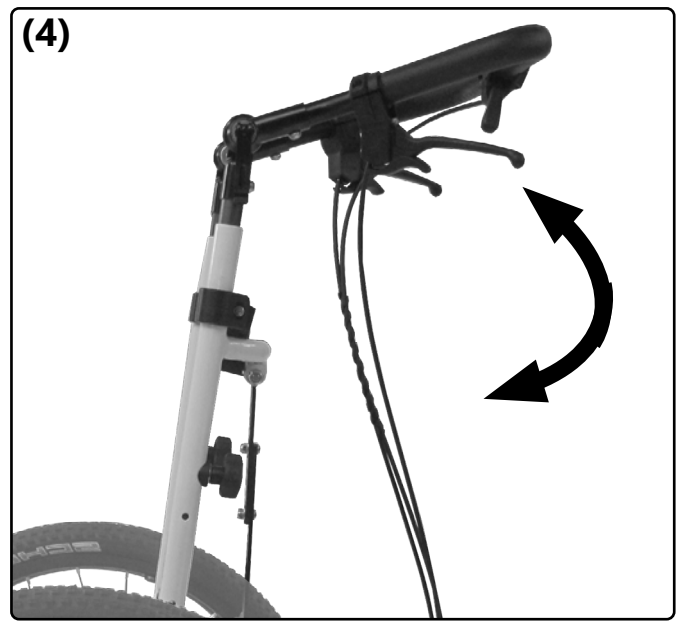
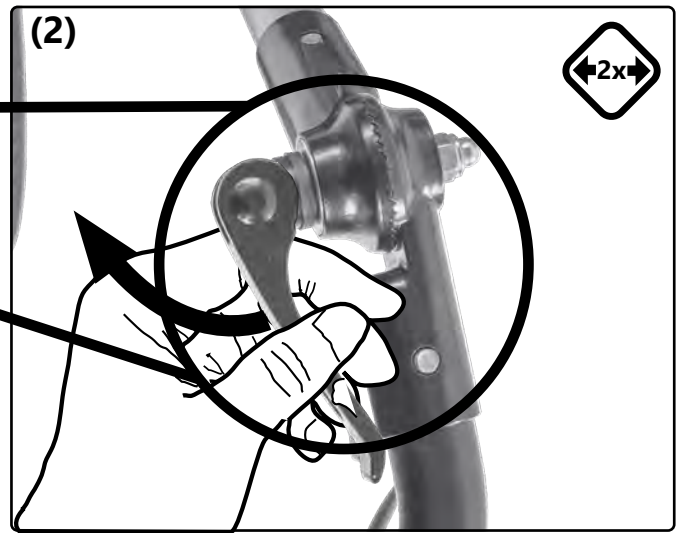
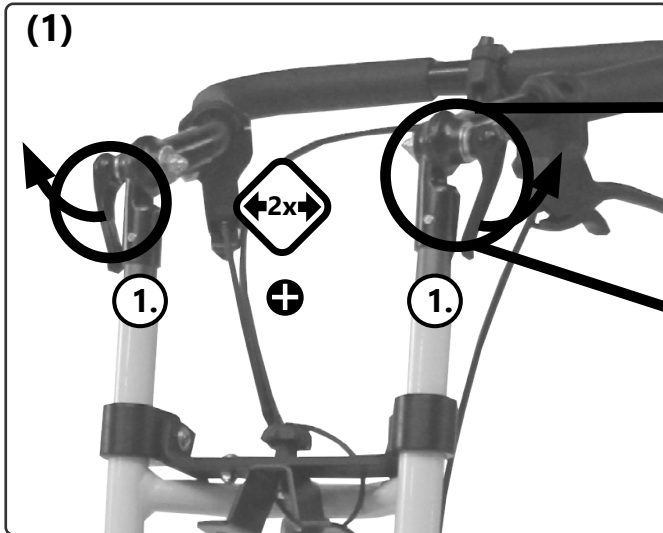

3.5 Handling leg support

3.5.1 General information regarding leg supports

Types of leg supports and their handling:

Standard leg support with continuous footrest:

Leg rest is angle adjustable and can be folded up to the back with continuous **(2a)** or divided **(2b)** footrest:

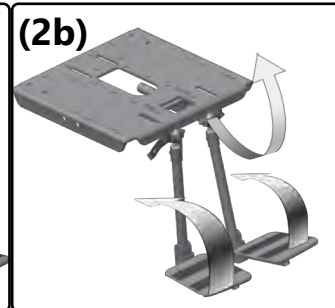
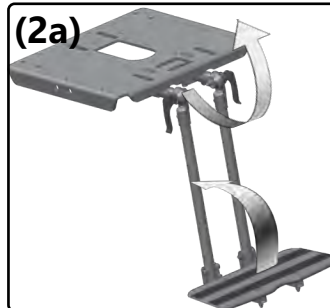
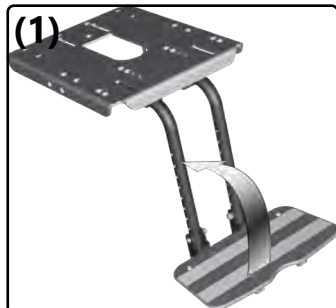

Multidirectional leg support:

Leg support can be swung outwards and detached:

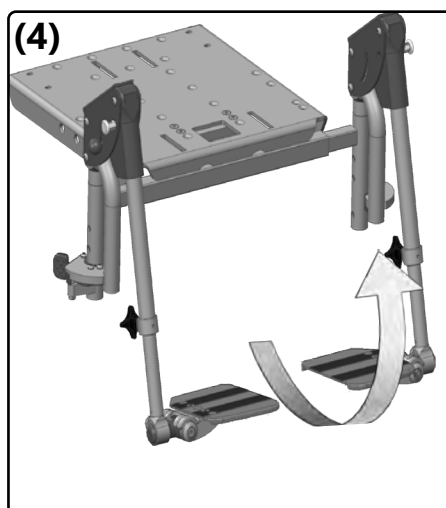
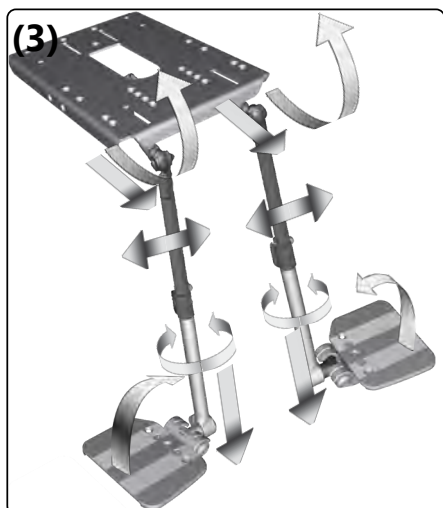

Leg rest can be detached, folded down and adjusted in width with continuous **(5a)** or divided footrest **(5b)**

Dynamic leg support:

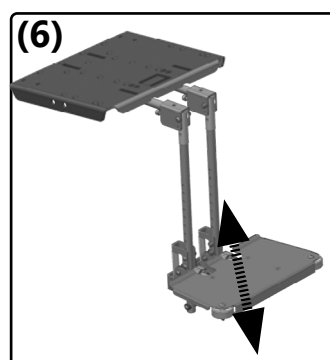
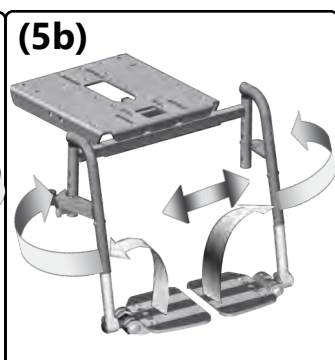
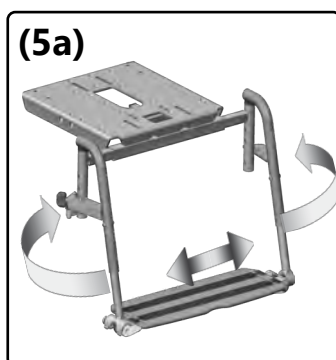

3.5 Handling leg support

3.5.2 Foldable footrest with locking mechanism

Lock (unlock: proceed accordingly in reverse order):

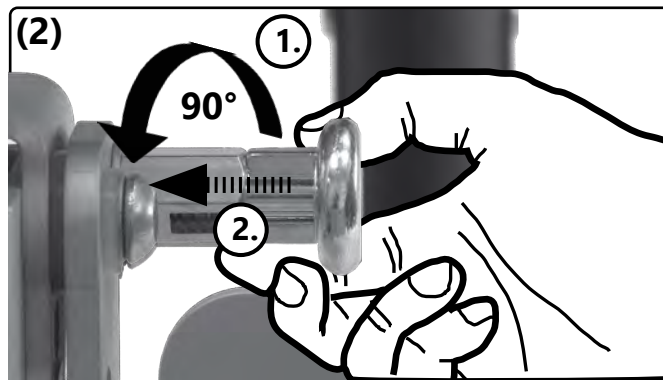

As the occupant, make sure that you do not lean too far out of the seat shell-underframe when handling the locking mechanism.

3.5 Handling leg support

3.5.3 Detachable and swivelling leg support

Attach (detach: proceed accordingly in reverse order):

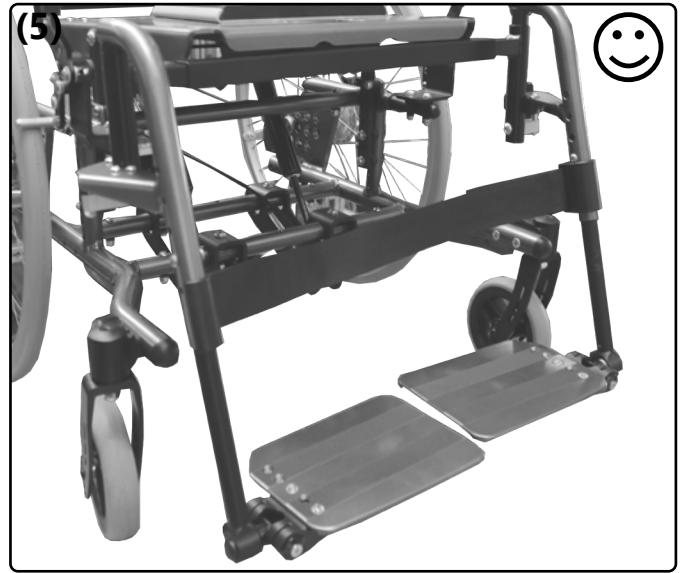
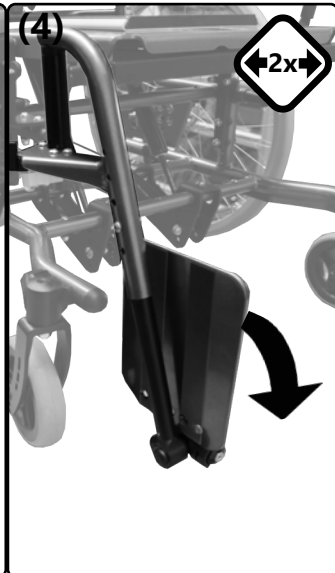
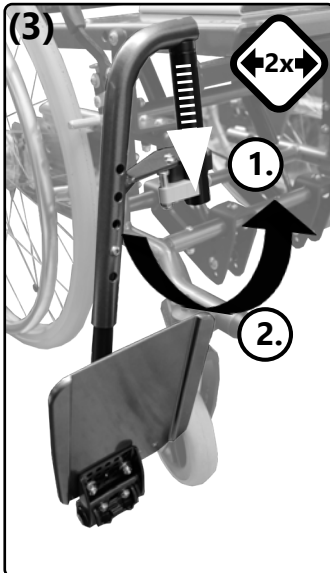
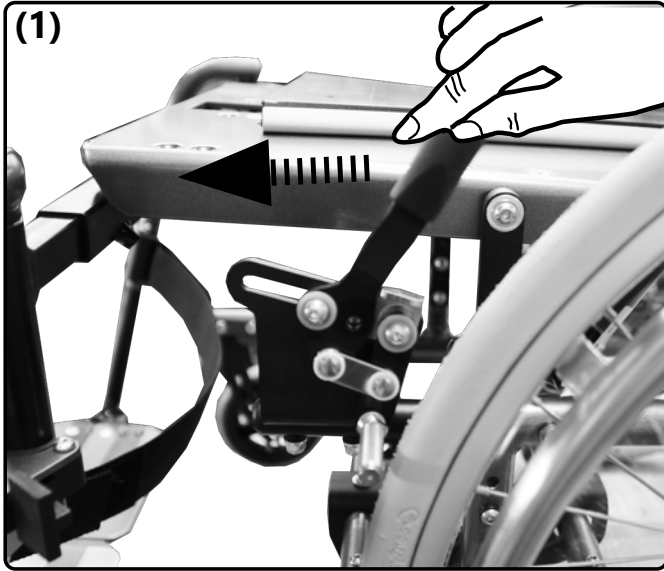

3.5 Handling leg support

Swivel out (swivel back: proceed accordingly in reverse order):

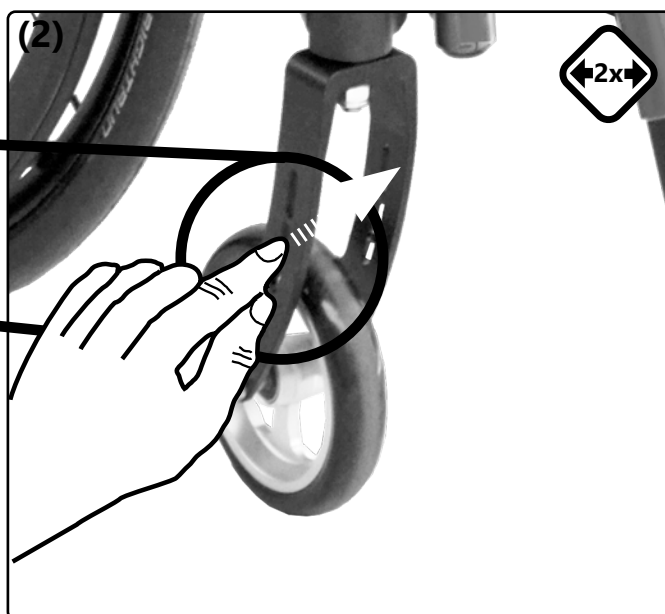
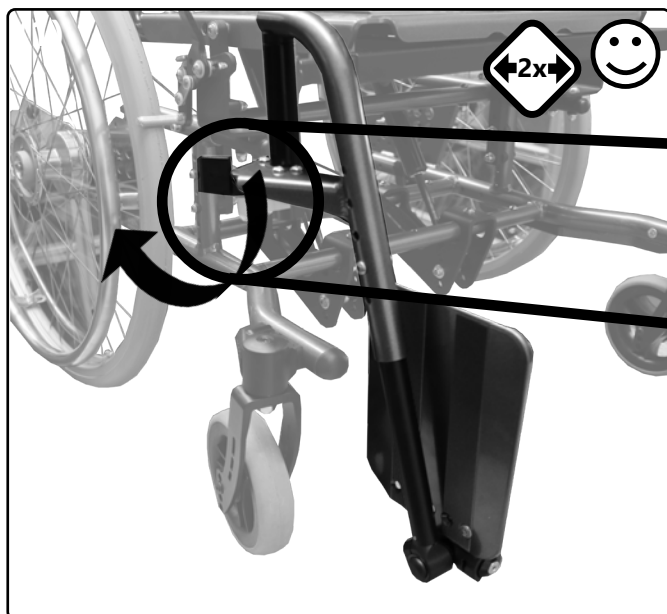

Set lower leg length:

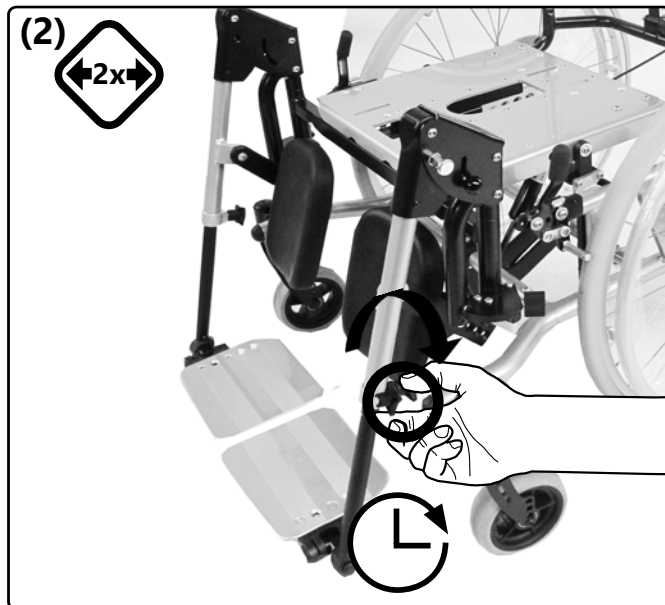
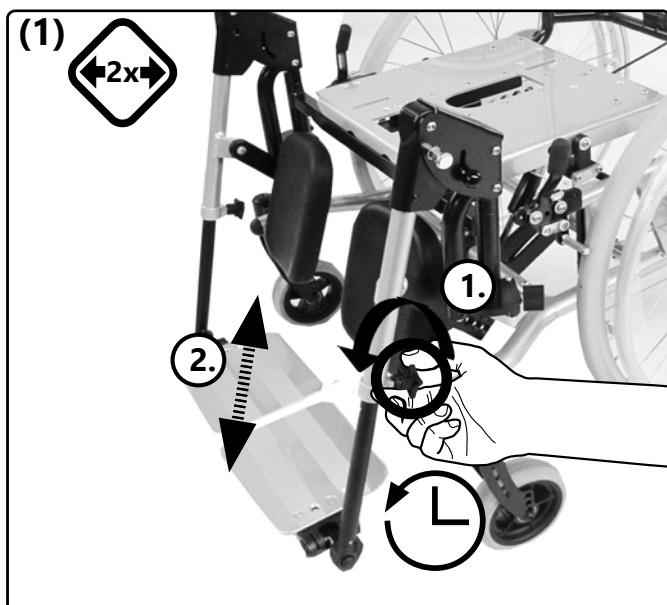

3.5 Handling leg support

Swivel up (swivel out: proceed accordingly in reverse order):

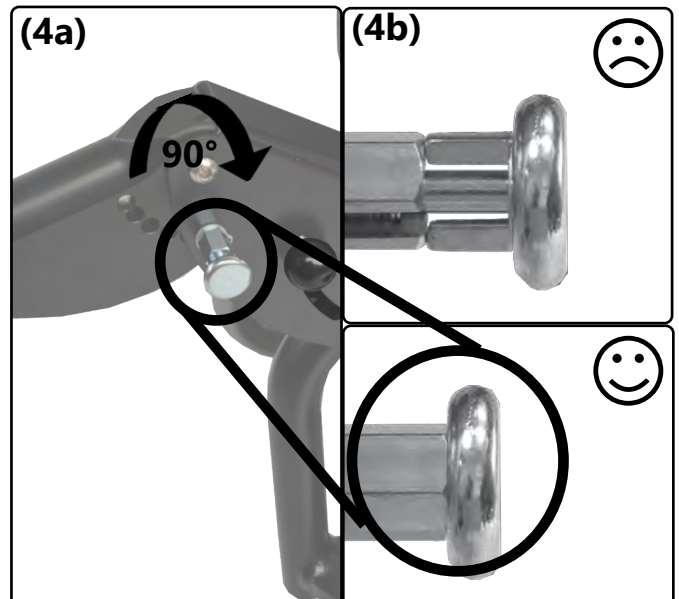
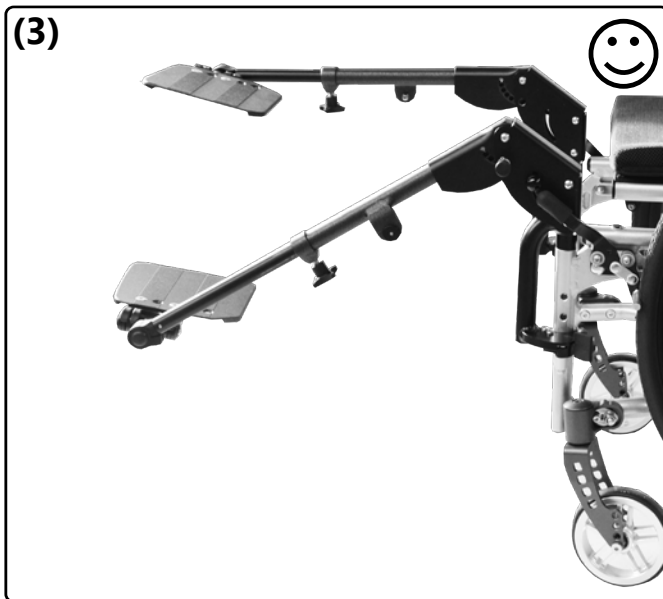
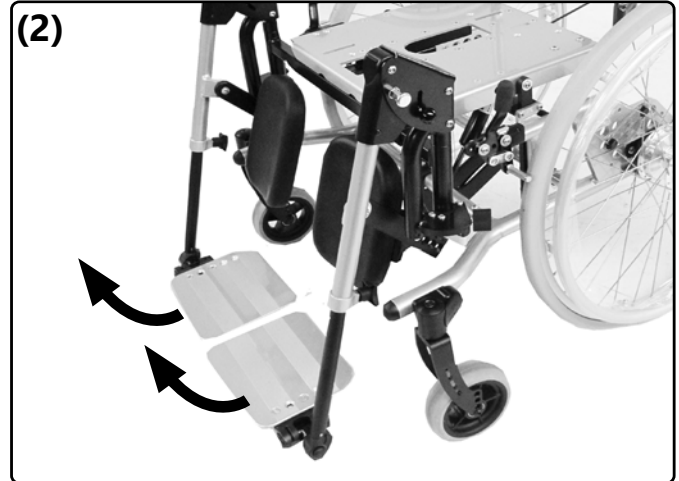
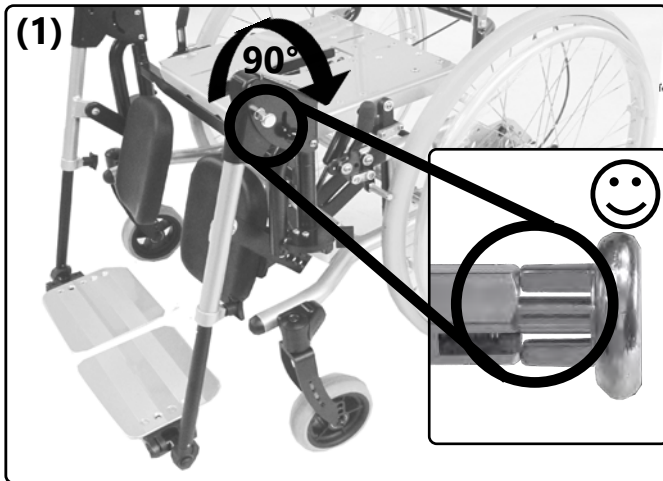

Swivel out: Proceed accordingly in reverse order:

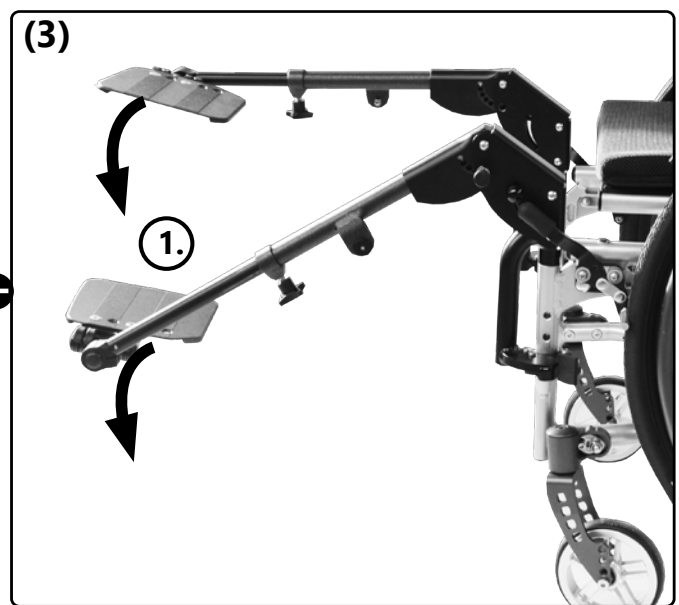
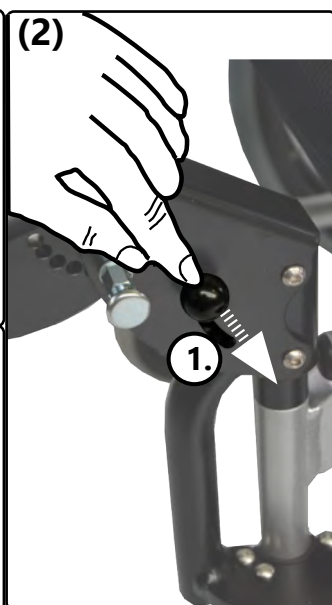
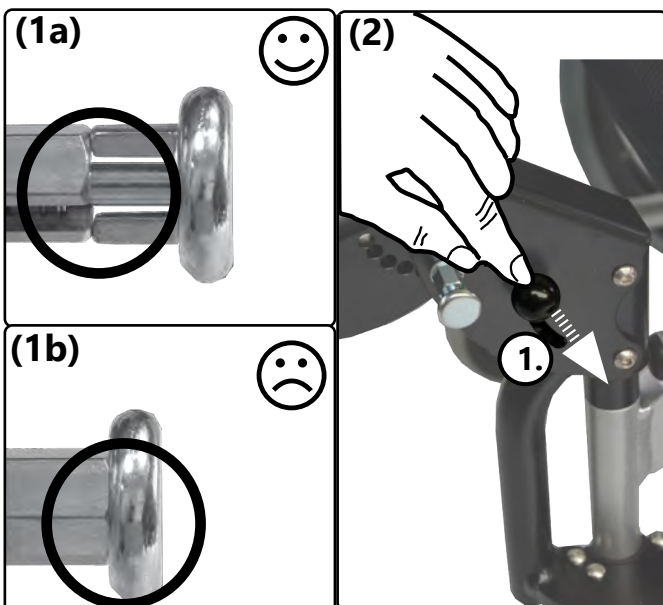

3.6 Handling brake

3.6.1 General information regarding brakes

Check that the brakes are in good working order before moving! Immediately contact your dealer if the braking effect deteriorates.

Possible impairments or malfunctions may be caused by:

- contaminated or incorrectly adjusted brakes,
- defective cable controls,
- too large a distance between brake pressure bolt and tyres,
- insufficient tyre inflation pressure (information on the tyre casing),
- wetness, snow, mud etc.,
- worn treads,
- worn or contaminated brake pressure bolts.

The seat shell-underframe cannot be used until the brakes have had any malfunctions rectified.

Always check that the brakes are locked securely and in working order on downhill gradients.

3.6.2 Wheel lock

The knee lever and cable control brakes are wheel locks and are **not** suitable for slowing down when moving.

Locking the wheel with the knee lever brake:

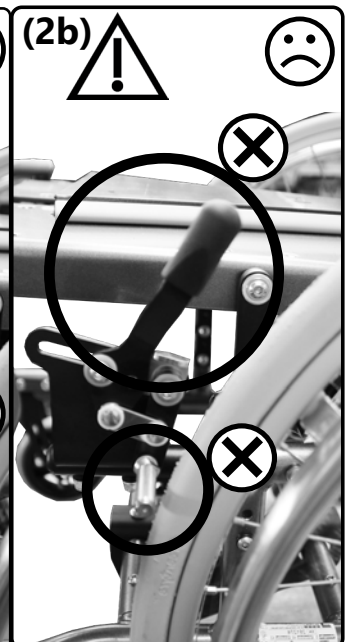
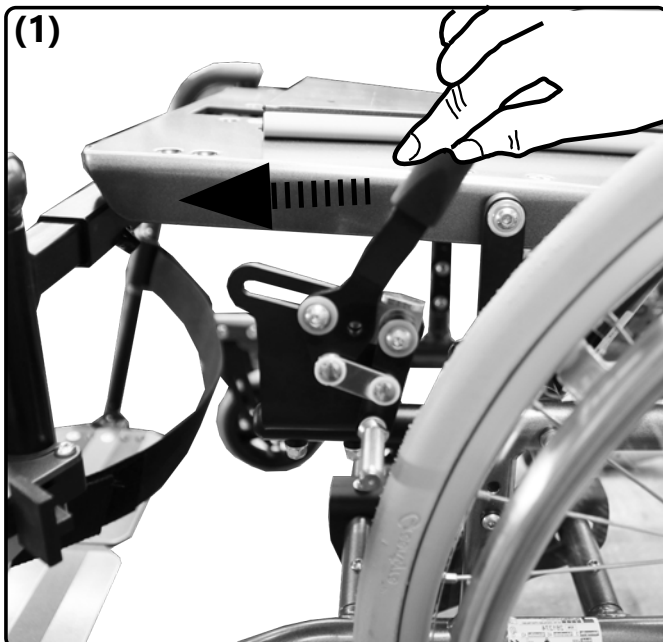

3.6 Handling brake

3.6.3 Drum brake

Slow down:



⚠ Unequal use of both brake levers results in cornering.

⚠ Clean the braking elements of the drum brake wheels at short intervals using a soft brush.

Lock:

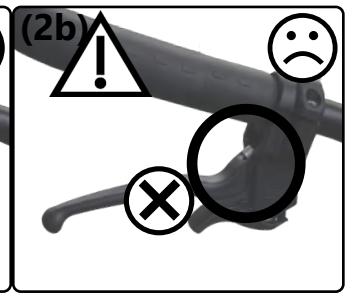
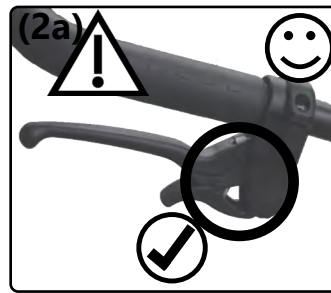
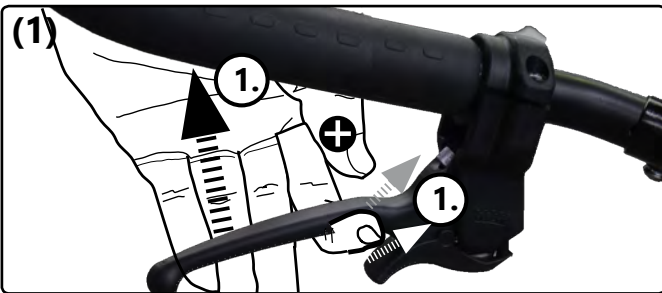

Release:



3.6.4 Reverse-roll locking

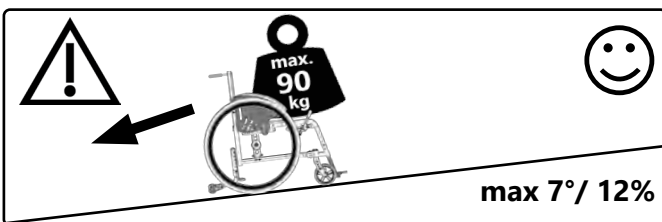

⚠ Not suitable in combination with auxiliary drives.

Activate (deactivate: proceed accordingly in reverse order):

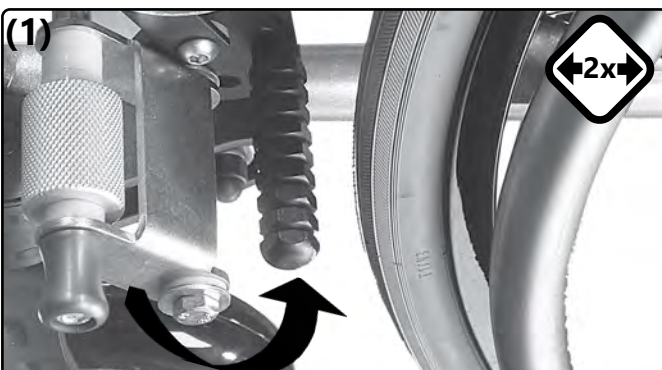

3.7 Handling anti-tipper

3.7.1 General information regarding anti-tipper

To improve tilting stability, a wheelbase extension, or at least an anti-tipper, must be used by people who have had leg amputations.

A wheelbase extension is **not** a replacement for an anti-tipper.

Activate:

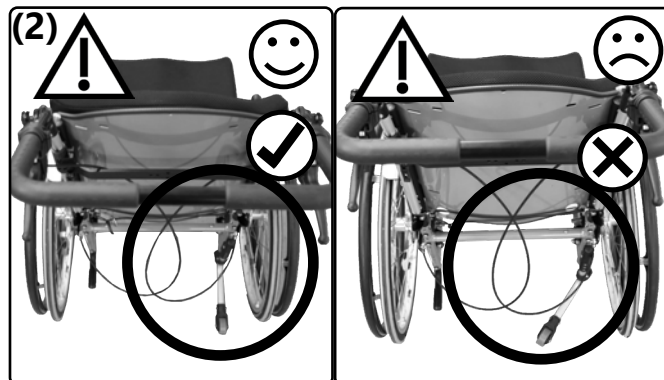
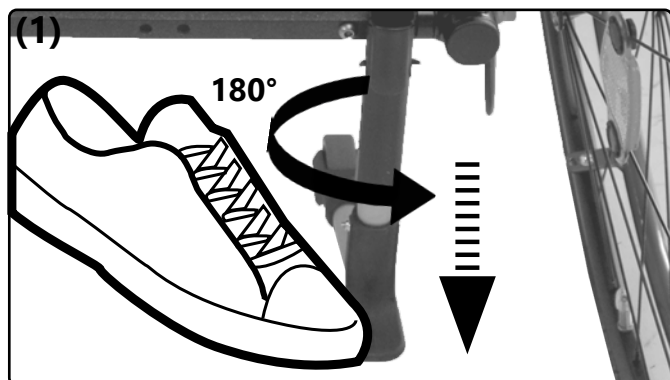

The anti-tipper must always be locked in its end position.

Deactivate:

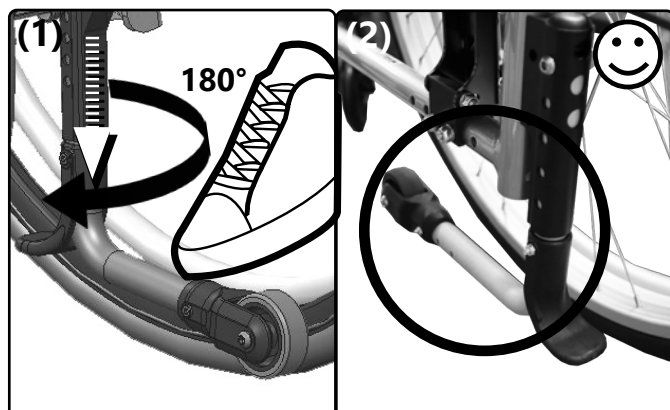

Only rotate the anti-tipper 180° from deactivated position to active position. Avoid full revolutions in one direction, since otherwise the tension spring inside the anti-tipper will be damaged, which may result in the anti-tipper losing its functionality.

3.8 Handling therapy table

3.8.1 General information regarding therapy table

Connection to the seat shell via the armrests.

Set depth or remove (insert: proceed accordingly in reverse order):

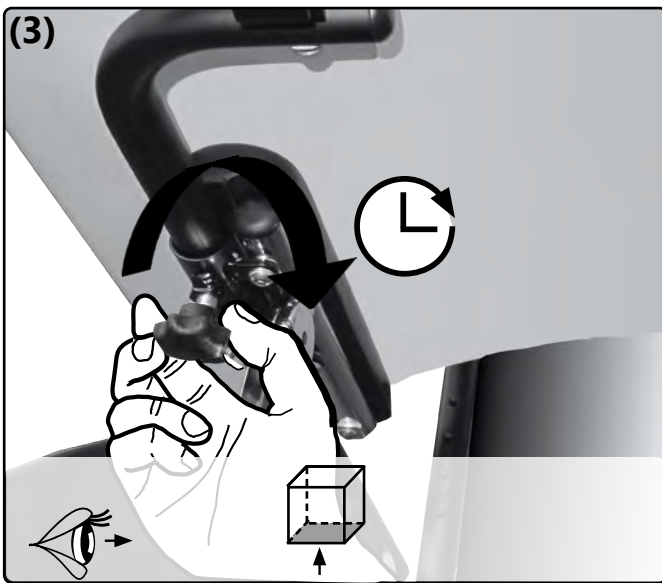
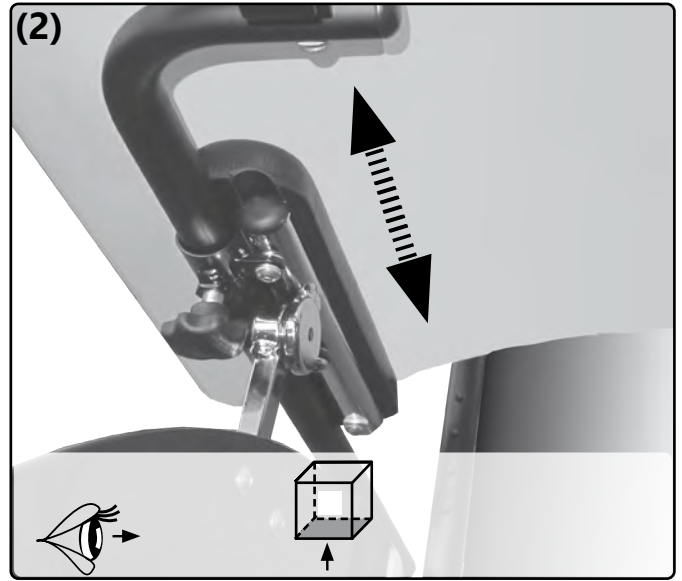
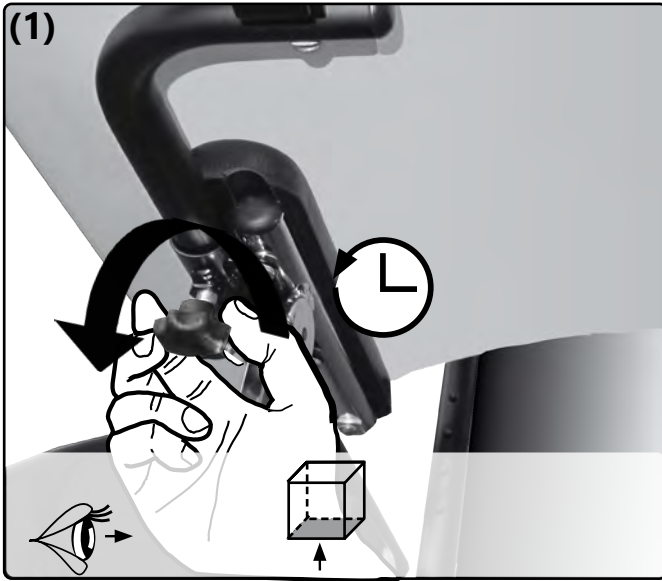

3.9 Handling arm pad

3.9.1 General information regarding arm pad

Connection directly to the back or over the seat shell.

3.9.2 Arm pad mounted on the back

Swivel up (swivel out: proceed accordingly in reverse order):

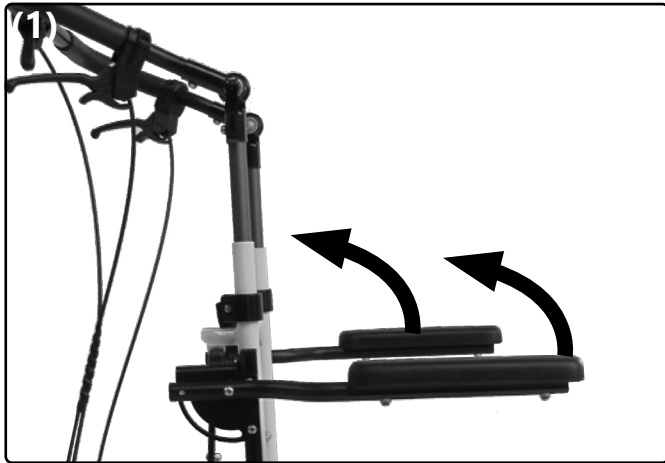

3.9.3 Arm pad mounted on the seat shell

Adjust angle:

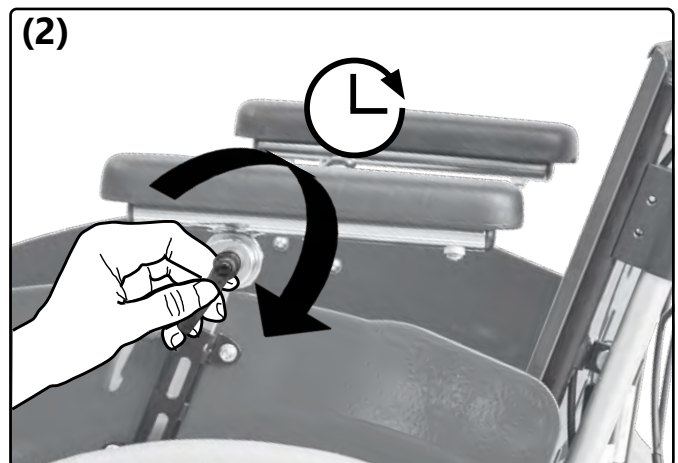
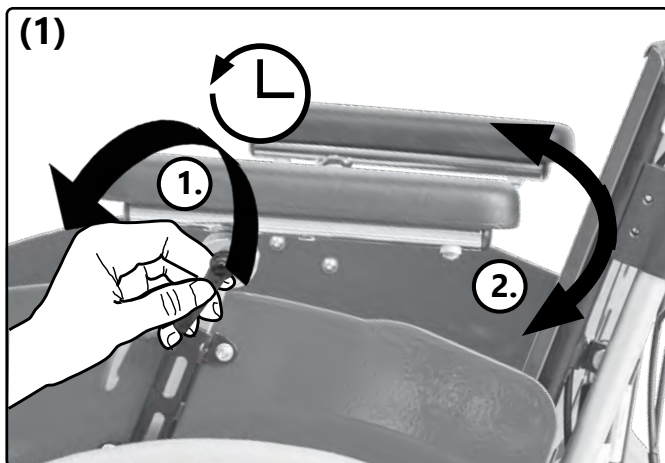

3.9 Handling arm pad

Infinitely variable height adjustment:

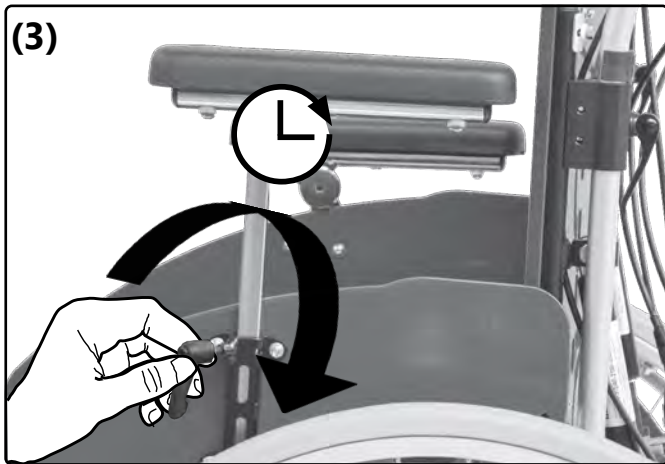
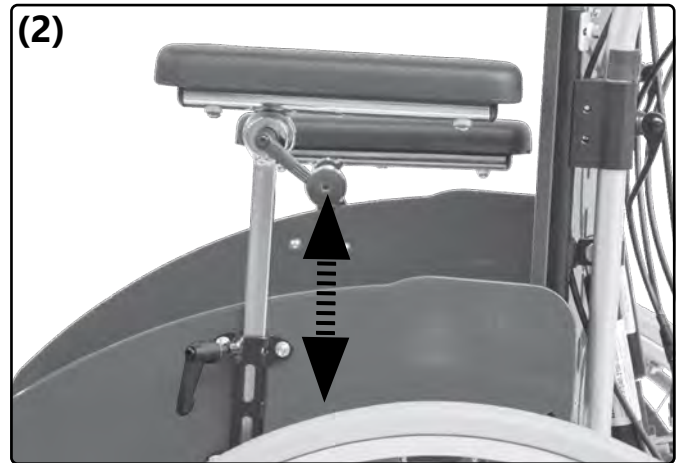
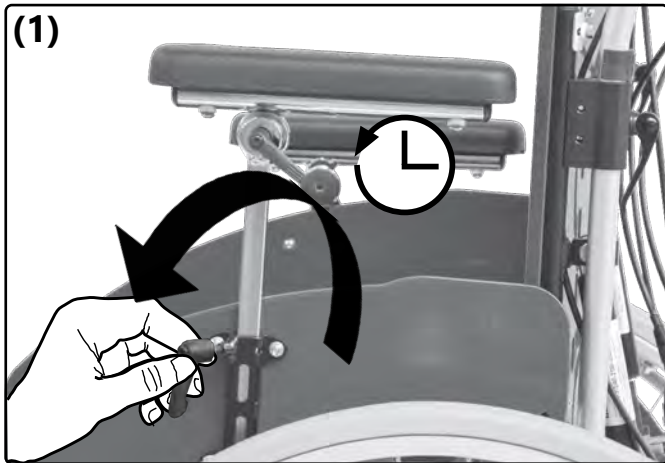

Set height with raster:

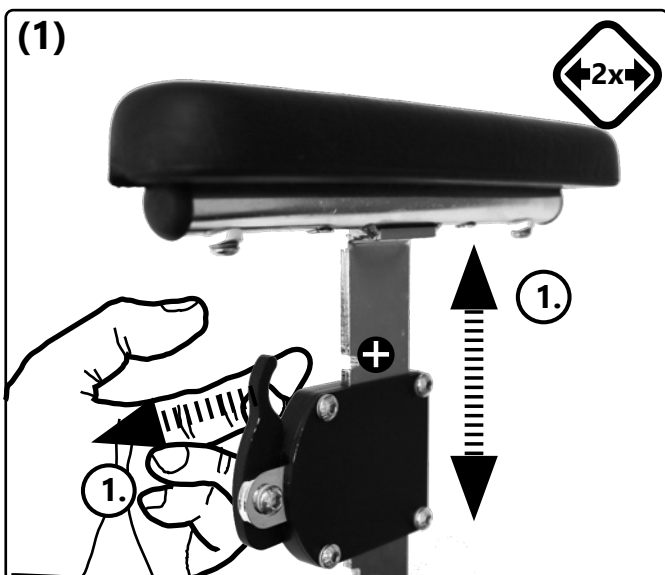

3.10 Handling steering & pushing aid

3.10.1 General information regarding steering and pushing aids

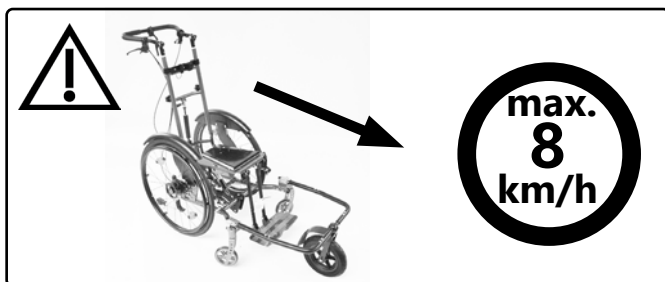

⚠ Pay attention to the max. load of the wheelchair, this also applies to the steering and pushing aid.

Mount (dismount: proceed in reverse order at Fig. 4):

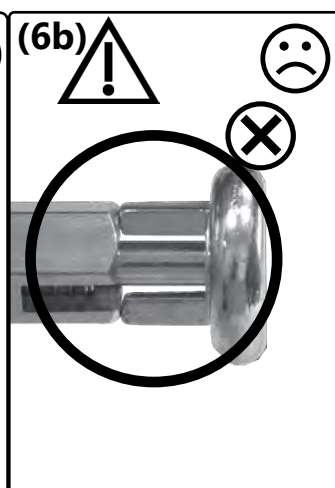
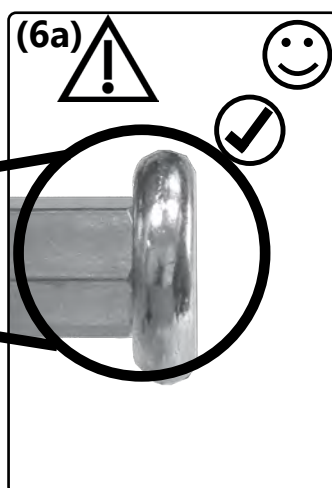
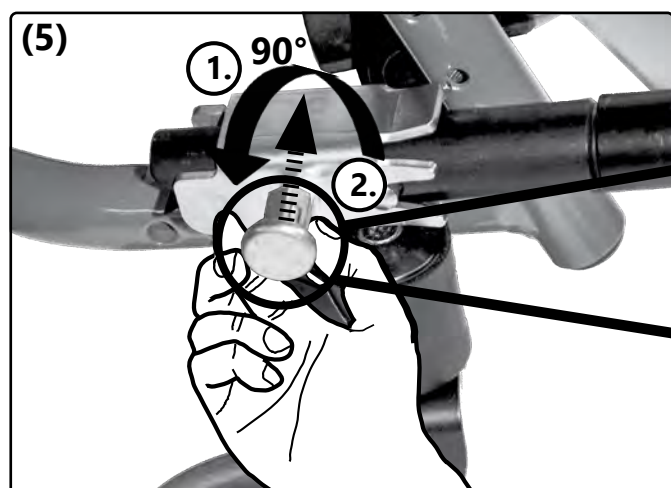
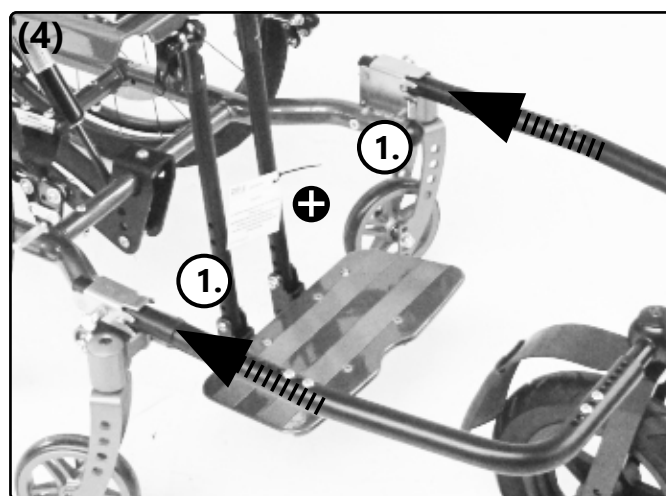
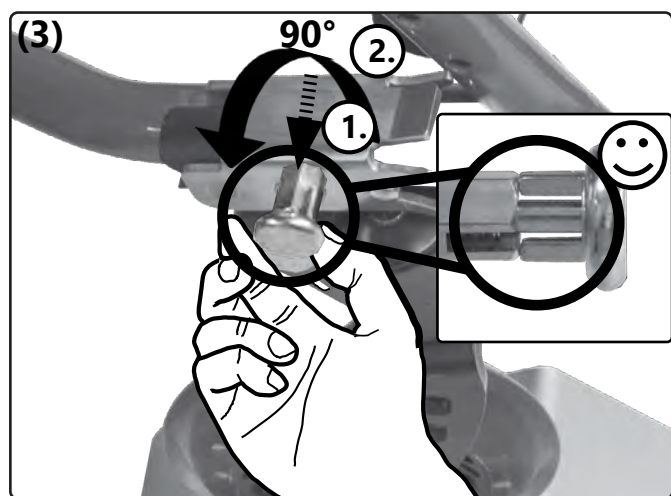
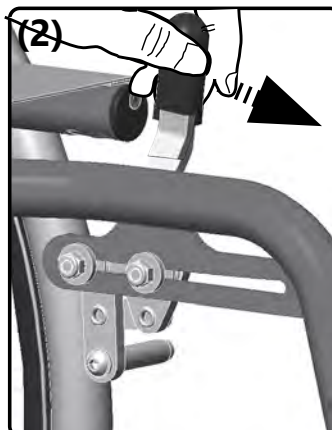
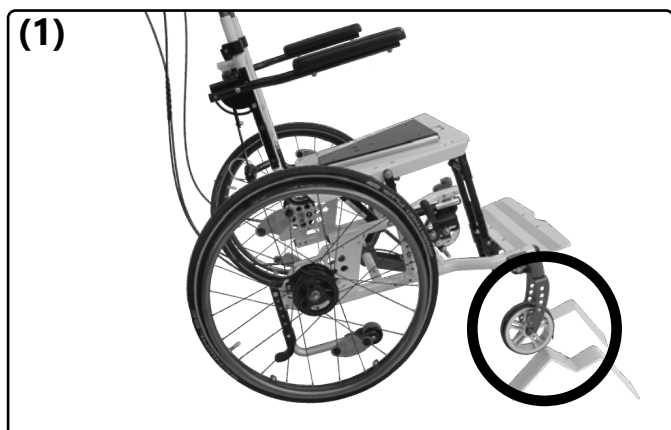

4.1 Repairs

 Repairs must only be carried out by a specialist dealer.

4.2 Spare parts

Only original replacement parts may be used. These can be obtained from your specialist dealer.

 The replacement parts list can be downloaded from www.sorgrollstuhltechnik.de or requested from us.

Please indicate the serial number of your seat shell-underframe to ensure correct replacement part delivery. This can be found on the nameplate on the frame.

4.3 Maintenance

Regularly clean the seat shell-underframe and all components using a mild, water-based household detergent and then dry thoroughly.

Also clean the driving and swivel casters and remove dirt and impurities (e.g. hair etc.) from the axles.

Washing textile parts:

Care instructions:

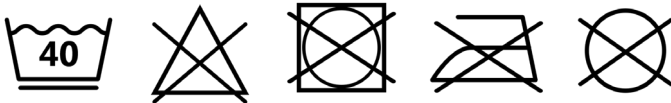

Wipe down imitation leather, belts and other upholstery:

Care instructions:

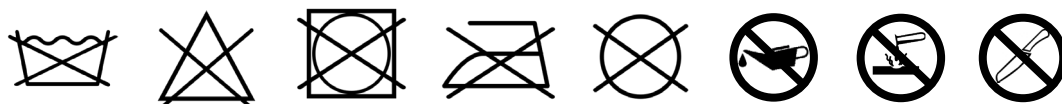

4.4 Disinfection

Cleaning must be carried out before each disinfection. Use a household water-based agent for disinfection. Please observe the application instructions of the respective manufacturer.

4.5 Storage

- Carry out cleaning
- Set (seating unit) tilt mechanism (if present) to 90°.
- Pack detachable textile parts in foil or the like, if necessary
- Secure the seat shell-underframe against rolling away and contamination
- Storage in a dry place without aggressive environmental influences

4.6 Lifespan

The expected lifespan, depending on the intensity of use and the number of re-uses, is 5 years. For this purpose, the product must be used within the intended purpose and intended use, the instructions in the instructions for use must be followed and all maintenance and service intervals must be observed.

The product can be used beyond this period if it is in a safe condition. This theoretical lifespan is not a guaranteed lifespan and is subject to a case-by-case check by specialist retailers, as is reusability.

Use beyond the specified lifespan leads to an increase in residual risks and should only be carried out after careful and qualified consideration by the operator.

The lifespan can also be shortened depending on the frequency of use, the environment and care. The usual service life does not refer to wear parts such as textile parts, wheels and plastic parts that are subject to material-specific aging and / or wear. This specified service life does not constitute an additional guarantee or guarantee.

4.7 Reinstatement

Before reuse, a full inspection according to the checklist must be carried out by a specialized retailer. All disinfection measures for reuse must be carried out according to a validated hygiene plan.

4.8 Disposal

The wheelchair may only be disposed of with the approval of the benefactor. Disposal of the wheelchair must be in accordance with the applicable national regulations.

4.9 Maintenance/Inspection

For safety reasons and to maintain product liability, an inspection by your retailer is required at least once a year. This must be carried out and documented according to the following checklist.

Checklist maintenance and care (user)

 A poor or neglected maintenance of the wheelchair represents a significant safety risk.

Before each use:

Please check:

- frame, back tubes, mounting parts and accessories for visible damages, deflections, cracks or missing/loose screws,
- wheels/quick release axles for firm fit,
- the airpressure of the tires, tire tread,
- the function of the brakes,
- firm fit of the angle adjustments/eccentric clamps,
- firm fit of seat plate/back/foot plate,
- the function of the anti-tipper/seat and back straps,
- if all previously dismantled parts are put on again or firmly locked.

Every 3 months:

(depending on use, earlier)

Please check:

- screws for firm fitting
- welds, attachments and accessories for hidden damages, deflections or cracks
- tire tread
- the firm fit of third-party systems (if available)

Clean the wheelchair and oil all moving parts.

 If you notice any defects during maintenance, please contact your specialist retailer immediately and do not use the wheelchair anymore.

Checklist yearly inspection (specialized retailer)

Template (available for download at www.sorgrollstuhltechnik.de/downloadportal)

Preparatory Work

- cleaning done

Check:

- Frame, back, mounted parts and accessories checked for damage, bends, cracks and corrosion,
- all fixing screws checked for firm fit and completeness,
- casters and rear wheels as well as the associated attachments checked for good condition, functionality and proper running qualities,
- spokes checked for firm fit and completeness,
- brakes cleaned and maintained,
- Locking mechanisms (tripod springs of push handles, quick-release axles, eccentric clamps, etc.) checked for functionality,
- anti-tipper checked for firm fit and functionality.

Oiling:

- moving parts and bearings oiled

Final check:

- functional check of all mechanical adjusting devices carried out.

5 Technical data

5.1 Data and measurements

Model: Loop^{SORG}

Type: 802

German Aid Index Nr.: 26.99.01.1078/ German Aid Index Nr.: 26.99.01.1045 with 12"/16"-wheels

All measurements ± 5%

Indication		Measurements	Comment
size 1	usable width = frame width + 40 mm	BH 300-420 mm in 40 mm steps	suitable from SD 320 mm, each BH + 40 mm growable
size 2	usable width = frame width + 40 mm	BH 340-460 mm in 40 mm steps	suitable from SD 380 mm, each BH + 40 mm growable
size 3	usable width = frame width + 40 mm	BH 380-500 mm in 40 mm steps	suitable from SD 440 mm, each BH + 40 mm growable
back height		430 or 580 mm	optionally
back unit		can be moved back	by approx. 60 mm
leg supports recording		about 60 mm forward	displaceable
tilting		from -5° to +35° from +2,5° to +40°	optionally
back angle	90 - 120°		
lower leg length	120 - 550 mm		
ETRTO wheel size	at 16"	Ø 400 mm	with drum brakes, Commercially available pneumatic tires in sizes 1 "(25.4mm), 1 3/8" (35mm) - sizes 355mm (20 "), 451mm (22"), 540mm, (24 ") All puncture-proof tires in the specified dimensions and 12" in size ETRTO 47-203
ETRTO wheel size	at 20"	Ø 451 mm	
ETRTO wheel size	at 22"	Ø 489 mm	
ETRTO wheel size	at 24"	Ø 540 mm	
ETRTO wheel size	at 12"	Ø 203 mm	
diameter handrim	at 20" at 22" at 24"	444 mm 481 mm 533 mm	
handrim		Ø 19 mm	diameter pipe
camber		0° or 2°	4° limited
Seat height (SH) with horizontal seat and horizontal frame	rear wheel 20"/22" caster 5"/5,5"	410 mm size 1 430 mm size 3	height adjustment +20/+40/+60 mm
	rear wheel 20"/22" caster 6"/7"	420 mm size 1 440 mm size 3	height adjustment +20/+40/+60 mm
	rear wheel 24" caster 5"/6"	430 mm size 1 450 mm size 3	height adjustment +20/+40/+60 mm
	rear wheel 24" caster 7"	445 mm size 1 465 mm size 3	height adjustment +20/+40 mm
	Wide seat shell base absolutely	min. max.	BH + 220 mm BH + 300 mm
Length of seat shell base frame absolutely	min.	610 mm at frame size 1, 12"-rear wheel and normal foot plate (160 mm)	
	max.	1130 mm at frame size 3, 24"-rear wheel, wheel base extension and wide footplate (230 mm)	
Height seat shell base frame absolutely	min.	900 - 1000 mm	at BH 430 mm and 45° push handle
	max.	1050 - 1150 mm	
	min.	1000 - 1100 mm	at BH 580 mm and 45° push handle
Height of seat shell base frame folded back	min.	1150 - 1250 mm	
	max.	550 mm 620 mm	
incline		12% = 7°	at 0° tilting and 0° back angle
descent		12% = 7°	
stability		12% = 7°	
turning circle		ca. 1100 mm	depending on the size
load capacity (max.)/ weight testdummy		120 kg	inkl. seat shell
tare	suitable for driving: BH 300 mm, rear wheel 12", caster 4"PU	15,1 kg	frame, seat plate, trum brake, handrim, caster, leg support, push handle, tilting-mechanism
heaviest piece	rear wheel	1,2 - 2,2 kg	
wheel		commercial pneumatic tires, sizes 1 ", 1 3/8" or puncture-proof tires (same dimensions), tire inflation pressure usually 3-10 bar	
corrosion protection	material	Stainless steel, aluminum	
	coating	Powder coating, galvanizing	
length of use of the wheelchair	3 years	at not excessive demand	
life cycle of the wheelchair	5 years		
Normative requirements	The wheelchair meets the requirements of ISO 7176-8 and the requirements against ignition.		

5 Technical data

5.2 Meaning of labels

The meaning of the individual labels can be directly derived from the text at the corresponding position.

A new nameplate can be obtained from SORG Rollstuhltechnik if the original one is lost or damaged.

Typeplate:

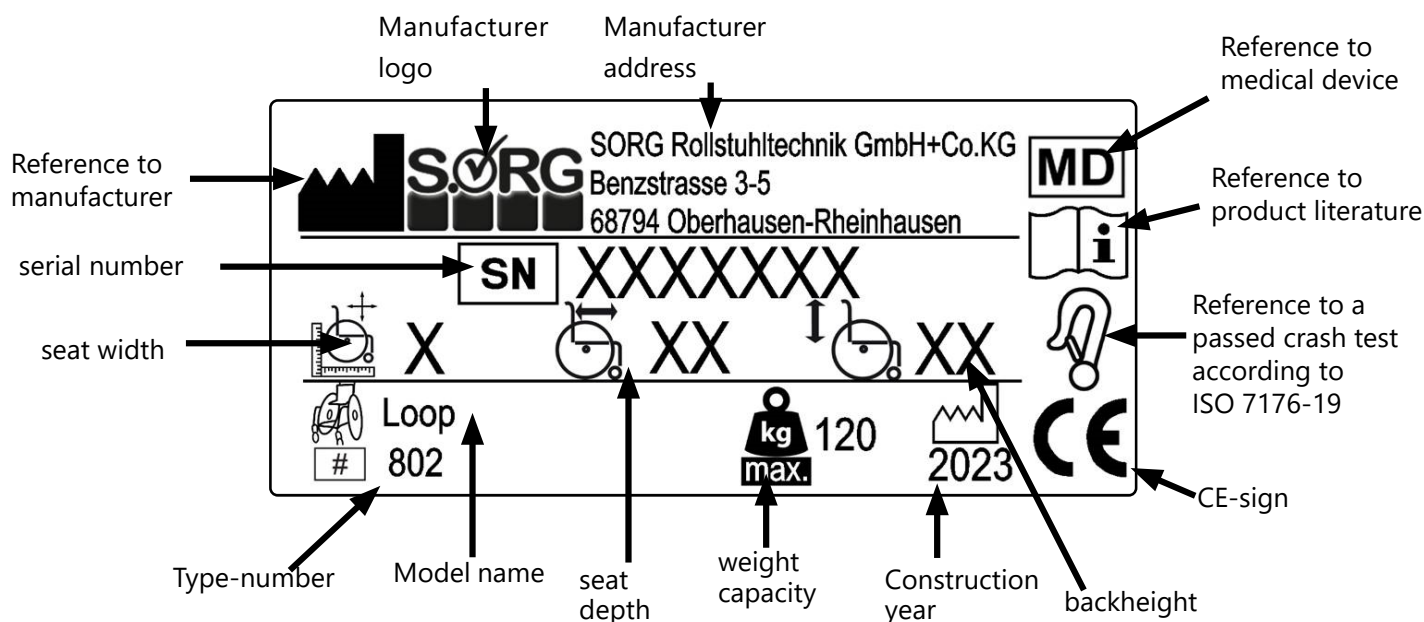

5.3 Declaration of conformity

SORG Rollstuhltechnik declares that the product Loop^{SORG} a class 1 device is and it complies with the EU regulation (EU) 2017/745 on medical devices.

This was confirmed by a conformity assessment procedure according to the medical Product Guidelines.

If the product is not modified with SORG wheelchair technology, this declaration will lose its validity.



6 Verification of yearly inspection

Documentation yearly inspection

An inspection must be carried out by your specialist dealer at least once a year for safety reasons and to preserve the product warranty.

Serial number: _____

- yearly inspection conducted according to check list (year 1)

comments:

Stamp:

 Date/ Retailer's signature

- yearly inspection conducted according to check list (year 2)

comments:

Stamp:

 Date/ Retailer's signature

- yearly inspection conducted according to check list (year 3)

comments:

Stamp:

 Date/ Retailer's signature

- yearly inspection conducted according to check list (year 4)

comments:

Stamp:

 Date/ Retailer's signature

- yearly inspection conducted according to check list (year 5)

comments:

Stamp:

 Date/ Retailer's signature



SORG Rollstuhltechnik GmbH + Co. KG
Benzstrasse 3-5
68794 Oberhausen-Rheinhausen / Germany
Germany
Phone +49 7254 9279-0
Fax +49 7254 9279-10

info@sorgrollstuhltechnik.de
www.sorgrollstuhltechnik.de



company stamp